

ETA 1727-1

TECHNICAL
COMMUNICATION

COMUNICACIÓN
TÉCNICA

COMUNICAZIONE
TECNICA

8³/₄"

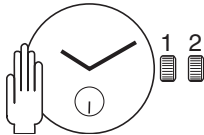
$8\frac{3}{4}"$ Ø 19,73 mm		
Height on movement Altura de máquina Altezza movimento	3,50 mm	
Running time / Reserva de marcha / riserva di marcia		50 h
Number of jewels / Número de piedras / Numero di pietre		19
Frequency / Frecuencia / Frequenza		21'600 A/h
Angle lift of balance / Ángulo de alzamiento / Angolo di alzamento		51°

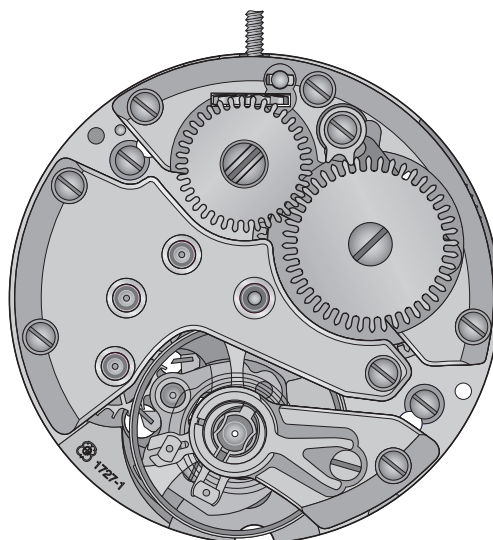
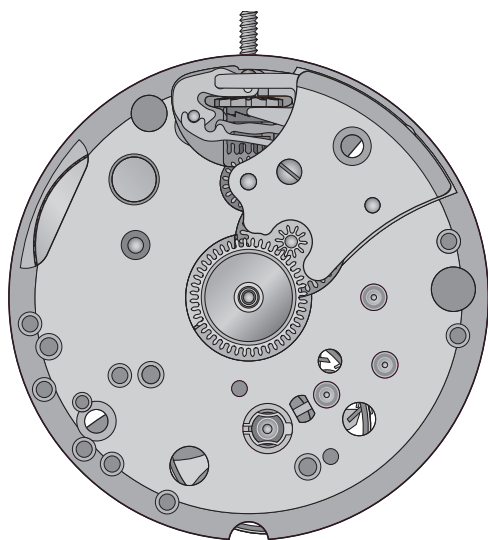

Interchangeability - Intercambiabilidad - Intercambiabilità











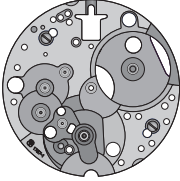

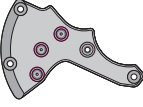

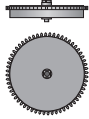

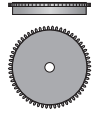



























Nr No No	Nr No CS No	LIST OF MATERIALS	LISTA DE FORNITURAS	ELENCO DELLE FORNITURE	Cal. Cal. Cal.
100	10.020.07	Main plate, jewelled	Platina, empedrada	Piastra, con pietre	1727-1
105	10.041.07	Barrel bridge, jewelled	Puente de cubo, empedrado	Ponte del bariletto, con pietre	1727-1
110	10.048.07	Train wheel bridge, jewelled	Puente de rodaje, empedrado	Ponte del ruotismo, con pietre	1727-1
121/3	10.058.61	Balance bridge, for regulator without pointer, for shock-absorber and stud support ETACHRON	Puente de volante, para raqueta sin flecha, para amortiguador y porta-pitón ETACHRON	Ponte del bilanciere, per racchetta senza freccia, per ammortizzatore e portapitone ETACHRON	1727-1
125	10.057.07	Pallet bridge, jewelled	Puente de áncora, empedrado	Ponte dell'ancora con pietre	1727-1
180/1	20.010.00	Movement barrel, complete	Cubo completo de máquina	Bariletto completo del movimento	1727-1
182	20.030.00	Barrel (drum and cover)	Cubo (tambor y tapa)	Bariletto (tamburo e coperchio)	1727-1
195	20.060.00	Barrel arbor	Árbol de cubo	Albero del bariletto	1727-1
201/1	30.014.00	Great wheel	Rueda grande de arrastre	Ruota di grande mediana	1727-1
210	30.025.00	Third wheel	Rueda primera	Ruota mediana	1727-1
227	30.027.00	Second wheel	Rueda de segundos	Ruota dei secondi	1727-1
240	31.080.00	Driver cannon pinion	Cañón de minutos arrastrador	Pignone calzante conduttore	1727-1
255/1	31.046.06	Hour wheel, assembled	Rueda de horas, ajustada	Ruota delle ore, montata	1727-1
260	31.041.00	Minute wheel	Rueda de minutería	Ruota della minutería	1727-1
301	40.301.00	Regulator	Raqueta	Racchetta	2982A2
301/1	40.301.06	Lower regular, assembled	Raqueta, ajustada	Racchetta, montata	1727-1
358	40.380.00	Corrector regular	Corrector de raqueta	Correttore della racchetta	1727-1
375	40.200.00	Stud support, ETACHRON	Porta-pitón, ETACHRON	Portapitone, ETACHRON	1727-1
401	51.010.21	Winding stem, thread diameter 0.90 mm	Tija de remontuar, diámetro de fileteado 0,90 mm	Albero di carica, diametro di filettatura 0,90 mm	1727-1
407	31.121.00	Sliding pinion	Piñón corredizo	Pignone scorrevole	1727-1
410	31.120.00	Winding pinion	Piñón de remontuar	Pignone di carica	1727-1
415	31.020.00	Ratchet wheel	Rochete	Rocchetto	1727-1
420	31.023.00	Crown wheel	Rueda de corona	Ruota a corona	1727-1
423	81.136.00	Crown wheel core	Sombrero de rueda de corona	Nocciolo della ruota a corona	1727-1
425	51.120.00	Click	Trinquete	Cricco	7001
430	61.080.00	Clic spring	Muelle de trinquete	Molla del cricco	7001
435	51.050.00	Yoke	Báscula de piñón corredizo	Bascula del pignone scorrevole	1727-1
443/1	51.080.06	Setting lever, assembled	Tirette, ajustado	Tiretto, montato	1727-1
445	51.090.00	Setting lever jumper	Muelle flexible de tirete	Scatto del tiretto	1727-1
450	31.100.00	Setting wheel	Rueda de transmisión	Rinvio	1727-1
462	10.062.00	Minute train bridge	Puente del rodaje de minutería	Ponte del ruotismo di minutería	1727-1
705	30.040.00	Escape wheel	Rueda de escape	Ruota di scappamento	1727-1
710	40.010.00	Pallet fork	Áncora	Ancora	1727-1
714	40.020.00	Pallet staff	Tija de áncora	Albero dell'ancora	1727-1
721/4	40.050.21	Timed annular balance, for shock-absorber and stud support ETACHRON	Volante anular regulado, para amortiguador y porta-pitón ETACHRON	Bilanciere anulare regolato, per ammortizzatore e portapitone ETACHRON	1727-1
728	40.100.21	Balance staff, for shock-absorber and annular balance	Eje de volante, para amortiguador y volante anular	Albero del bilanciere, per ammortizzatore e bilanciere anulare	1727-1
730	40.120.00	Double roller	Platillo doble	Doppio-disco	1727-1
770	20.100.00	Mainspring	Muelle motor	Molla-motrice	1727-1
3024	70.530.00	Jewelled shock-absorber for balance, top, to press in, shouldered	Amortiguador, empedrado, de volante, de embutir, de asiento, encima	Ammortizzatore, con pietre, del bilanciere, a pressione, con piano d'appoggio, sopra	7001
3025	70.531.00	Jewelled shock-absorber for balance, bottom, to press in, cylindrical	Amortiguador, empedrado, de volante, de embutir, cilíndrico, debajo	Ammortizzatore, con pietre, del bilanciere, a pressione, cilindrico, sotto	7001
5101	10.020.01	2x Case screw	Tornillo de fijación	Vite di fissaggio	7001
5102	10.020.02	2x Case screw, special	Tornillo de fijación, especial	Vite di fissaggio, speciale	1727-1
1) 5105	10.041.01	3x Screw for barrel bridge	Tornillo del puente de cubo	Vite del ponte del bariletto	1727-1
1) 5110	10.048.01	3x Screw for train wheel bridge	Tornillo del puente de rodaje	Vite del ponte del ruotismo	1727-1
1) 5121	10.058.01	1x Screw for balance bridge	Tornillo del puente de volante	Vite del ponte del bilanciere	1727-1
5125	10.057.01	1x Screw for pallet bridge	Tornillo del puente de áncora	Vite del ponte d'ancora	7001

Interchangeability - Intercambiabilidad - Intercambiabilità

Nr No No	Nr No CS No		LIST OF MATERIALS	LISTA DE FORNITURAS	ELENCO DELLE FORNITURE	Cal. Cal. Cal.
5415	31.020.01	1x	Screw for ratchet wheel	Tornillo del rochete	Vite per il rocchetto	7001
5420	31.023.01	1x	Screw for crown wheel, lefthanded thread	Tornillo de la rueda de corona	Vite per la ruota a corona	1727-1
5425	51.120.01	1x	Screw for click	Tornillo del trinquete	Vite del cricco	7001
2) 5445	51.090.01	1x	Screw for setting lever jumper	Tornillo del muelle flexible de tirete	Vite dello scatto del tiretto	1727-1
2) 5462	10.062.01	1x	Screw for minute train bridge	Tornillo del puente de rodaje de minutería	Vite del ponte del ruotismo di minuteria	1727-1
Identical screws 1) 5105 2) 5445 Tornillos idénticos 5110 5462 Vite identiche 5121						

Screws Tornillos Vite	M _L Minimum torque for loosing M _L Par mínimo para desatornillar M _L Coppia minima per svitare
5101	1,1 Ncm
5102	1,1 Ncm

Materials - Fornituras - Forniture

							5101			
100	105	110	121/3	125	180/1		5102			
										5105 5110 5121
182	195	201/1	210	220	240	255/1	260	301		5125
									5415	
301/1	358	375	401	407	410	415	420		5420	
									5425	
423	425	430	435	443/1	445	450	462		5445 5462	
								3024	3025	
705	710	721/4	728	730	770	3024	3025			

Assembling of the handsetting mechanisms

(Parts listed in order of assembly)

Montaje de los mecanismos de puesta en hora

(Lista de fornitureas por orden de ensamblado)

Montaggio dei meccanismi della messa all'ora

(Elenco delle forniture per ordine di montaggio)

100	5445
401	240
410	260
407	450
443/1	462
435	5462
445	255/1

Lubrication – Lubricación – Lubrificazione

Thick pressure-resistant oil or grease



Viscosidad elevada o grasa
Olio denso a viscosità elevata o grasso

Moebius D5

or / ó / o
HP 1300

Very small quantity



Cantidad muy pequeña
Piccolissima quantità

Moebius D5

or / ó / o
HP 1300

Grease



Grasa
Grassa

Jismaa 124

or / ó / o
Moebius 9501

M_L Minimum torque for loosening

M_L Par mínimo para desatornillar

M_L Coppia minima per svitare

(a) 0,6 Ncm

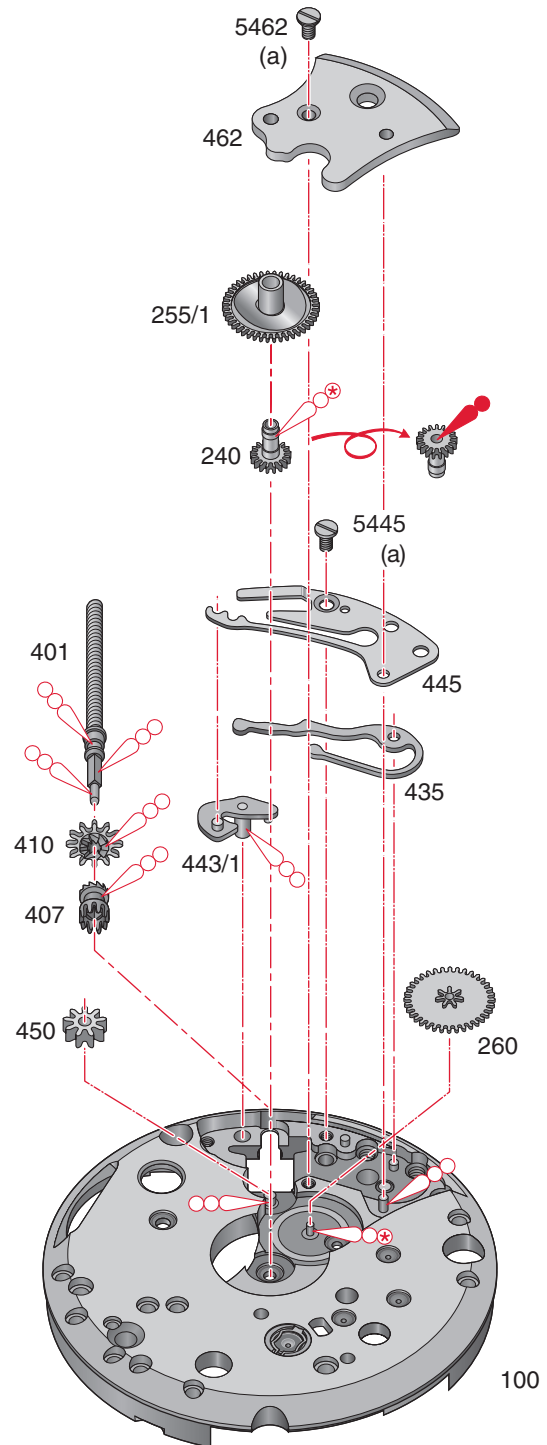

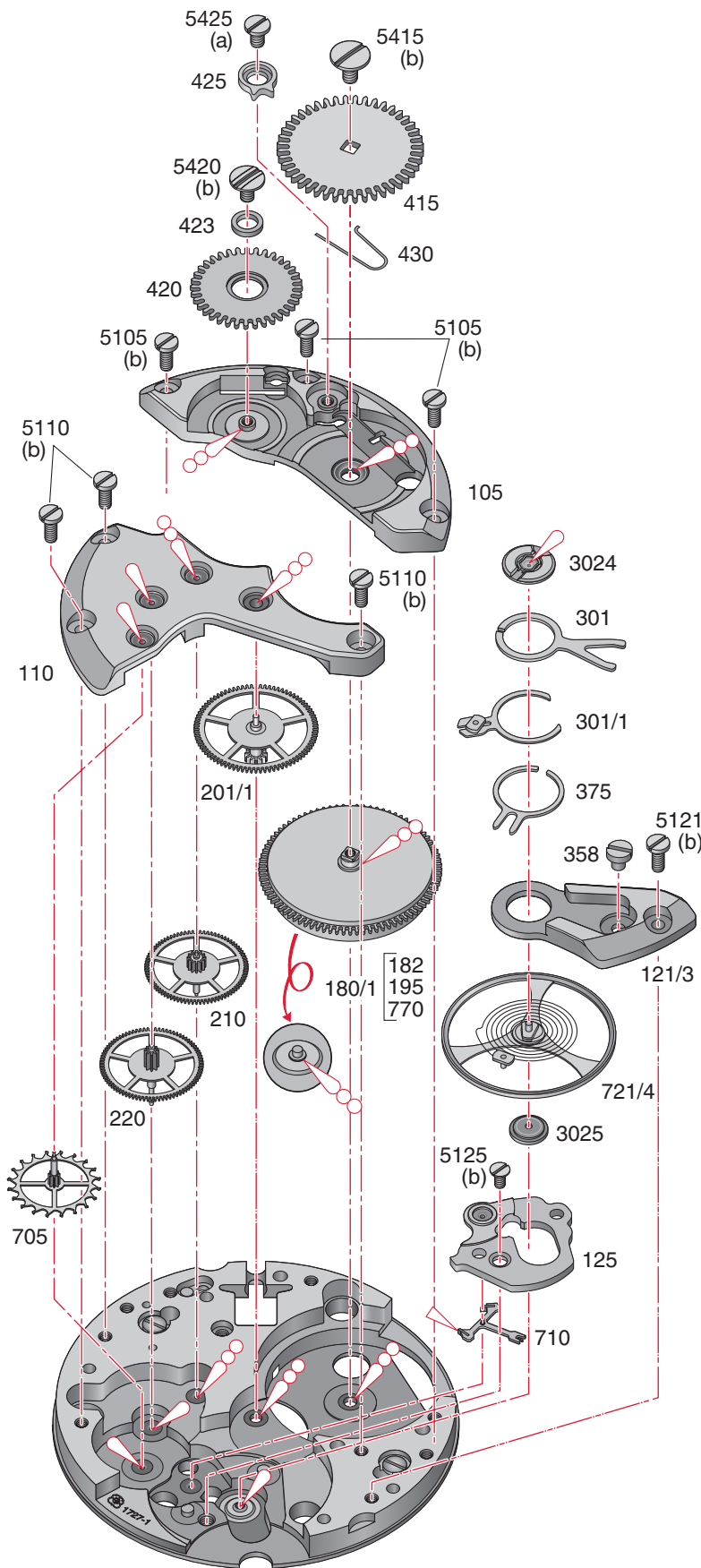

Assembling of the basic movement

(Parts listed in order of assembly)

Montaje de la máquina de base

(Lista de fornitureas por orden de ensamblado)

Montaggio del movimento di base

(Elenco delle forniture per ordine di montaggio)

100		721/4	
3025		121/3	
705		358	
220		301/1	
210		375/1	
201/1		301	
110		3024	
5110	(3x)	5121	(1x)
		423	
180/1		420	
		195	
		770	5420
105		430	
5105	(3x)	425	
710		5425	(1x)
125		415	
5125	(1x)	5415	(1x)

Lubrication – Lubricación – Lubrificazione

	Fine oil Aceite fino Olio fluido	Moebius 9010
	Thick oil or grease Aceite espeso o grasa Olio denso o grasso	Moebius D5 or / ó / o HP 1300
	Special oil for pallet stones Aceite especial para escape Olio speciale per scappamento	Moebius 941 or / ó / o Moebius 9415

M_L Minimum torque for loosening

M_L Par mínimo para desatornillar

M_L Coppia minima per svitare

(a)	0,6	Ncm
(b)	0,7	Ncm

We reserve all rights for this document. It is meant for the recipient only and it may not be copied, printed or given to a third person without our written permission.

Quedan reservados todos los derechos relacionados con este documento, que está dirigido únicamente al destinatario. Queda por lo tanto prohibida su copia, impresión o cesión a terceros sin nuestra autorización por escrito.

Ogni diritto su questo documento è riservato. Il documento è indirizzato esclusivamente al destinatario e non può essere copiato, stampato o ceduto a terzi senza un'autorizzazione scritta.

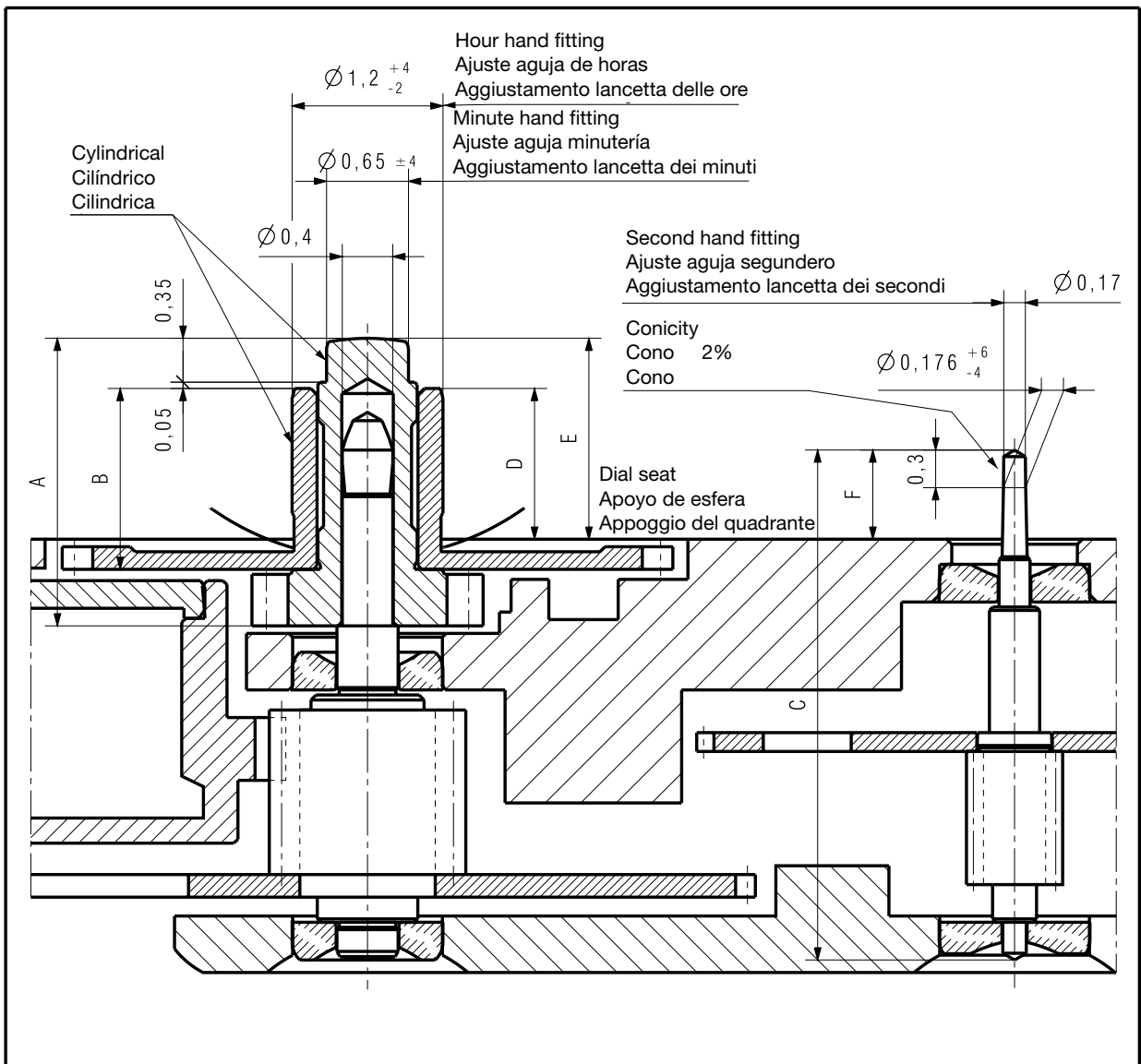

Hand fitting heights Ajuste de la agujas Aggiustamento lancette	Length / Longitudes / Lunghezze			Height over dial seat Exceso en mm en relación con la platina Sorpassi in mm rispetto alla piastra		
	A	B	C	D	E	F
1 normal	2,27	1,44	4,06	1,20	1,60	0,75
2	2,52	1,69	4,06	1,45	1,85	0,75
3	2,77	1,94	4,06	1,70	2,10	0,75

Kaliber / Calibre / Caliber		Massestab Echelle Scale		CATIA V5			
1727-1				Masse in mm Dimensions en mm Dimensions in mm		Tol.1/1000 mm	
Hand fitting height Ajuste de la agujas Aggiustamento lancette			Z0059632	Version 02	Revision 00	Blatt Feuille Sheet 01	
Ersatz für En remplacement de Rimpiazzamento per			Klass. ZVACC		KUN		
Aenderung Modification	Geprüft Contrôlé Controlled	Freigegeben Libéré Released			Erstellt Etabli Created	Geprüft Contrôlé Controlled	Freigegeben Libéré Released
17837	MEA	11.08.2003 JPR	ETA SA Manufacture Horlogère Suisse CH-2540 Grenchen A COMPANY OF THE SWATCH GROUP		24.07.2002 MEA	23.09.2002 EBR	23.09.2002 FEU

*Modifications compared with
previous document versions*

*Modificaciones comparadas con
las versiones anteriores del docu-
mento*

*Modifiche comparate con le ver-
sioni precedenti del documento*

Version Versión Versione	Date Fecha Data	Modification	Modificación	Modifica	Page Página Pagina
02	17.03.06	Basic version	Versión de base	Versione di base	--



ETA SA Manufacture Horlogère Suisse

Customer Service

Bahnhofstrasse 9

P.O. Box 359

CH - 2540 Grenchen

Phone: +41 (0)32 655 27 77

Fax: +41 (0)32 655 84 30

e-mail: etacs@eta.ch

www.eta.ch