

Coordinates	
Mark	X Y
GM	0 0
DH7	9207 8080
DH8	-7522 -9668
DH9	-10045 7012
DH10	9700 -7481
DH11	-8662 -8662

DH7~DH8=24390 (±20)
 DH7~DH11=24487 (±20)
 DH9~DH10=24493 (±20)

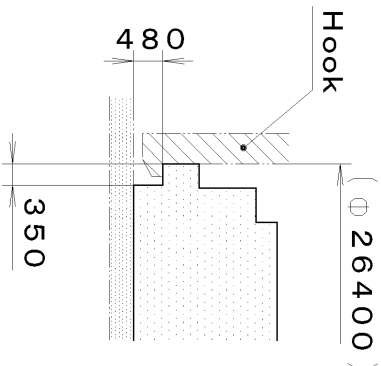
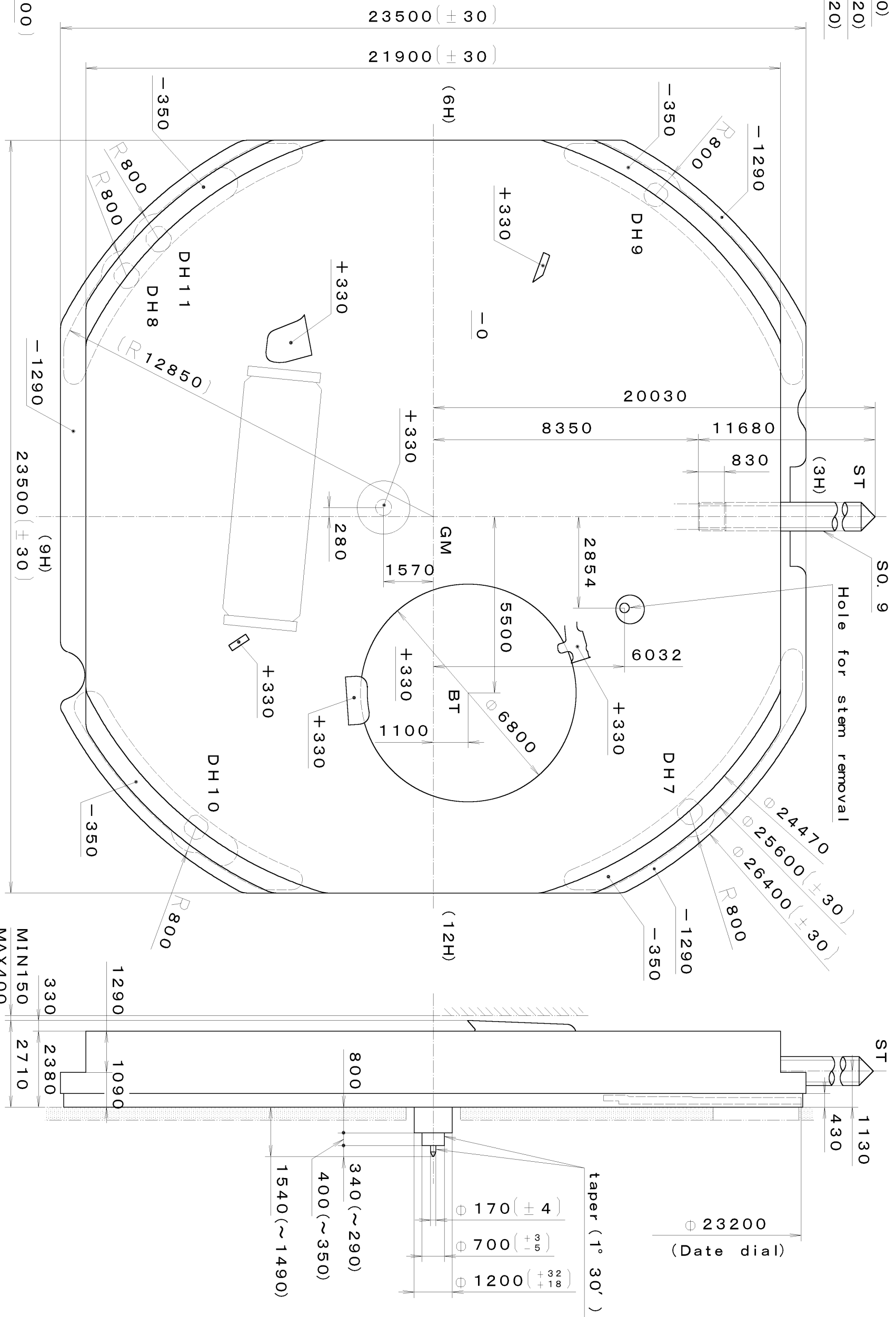

Hook of Casing Holder

Quantity	Unit	1/1000 mm	Cal. No. : 1S13
Scale	8:1		Parts:
Date			Name:
Drawn			Frame for Case
Checked		T. Hiruta	Drawing No. : 1S13C0000
Approved			
Material			
Heat Treatment			
Hardness			
Plating			
General Tolerances			
Dimensions			
Angles			

MIYOTA

This drawing is provisional and subject to our reconfirmation and/or revision without notice.

*** T I P W 1S13-10A (01) *** (2100 1121) 03-11-06

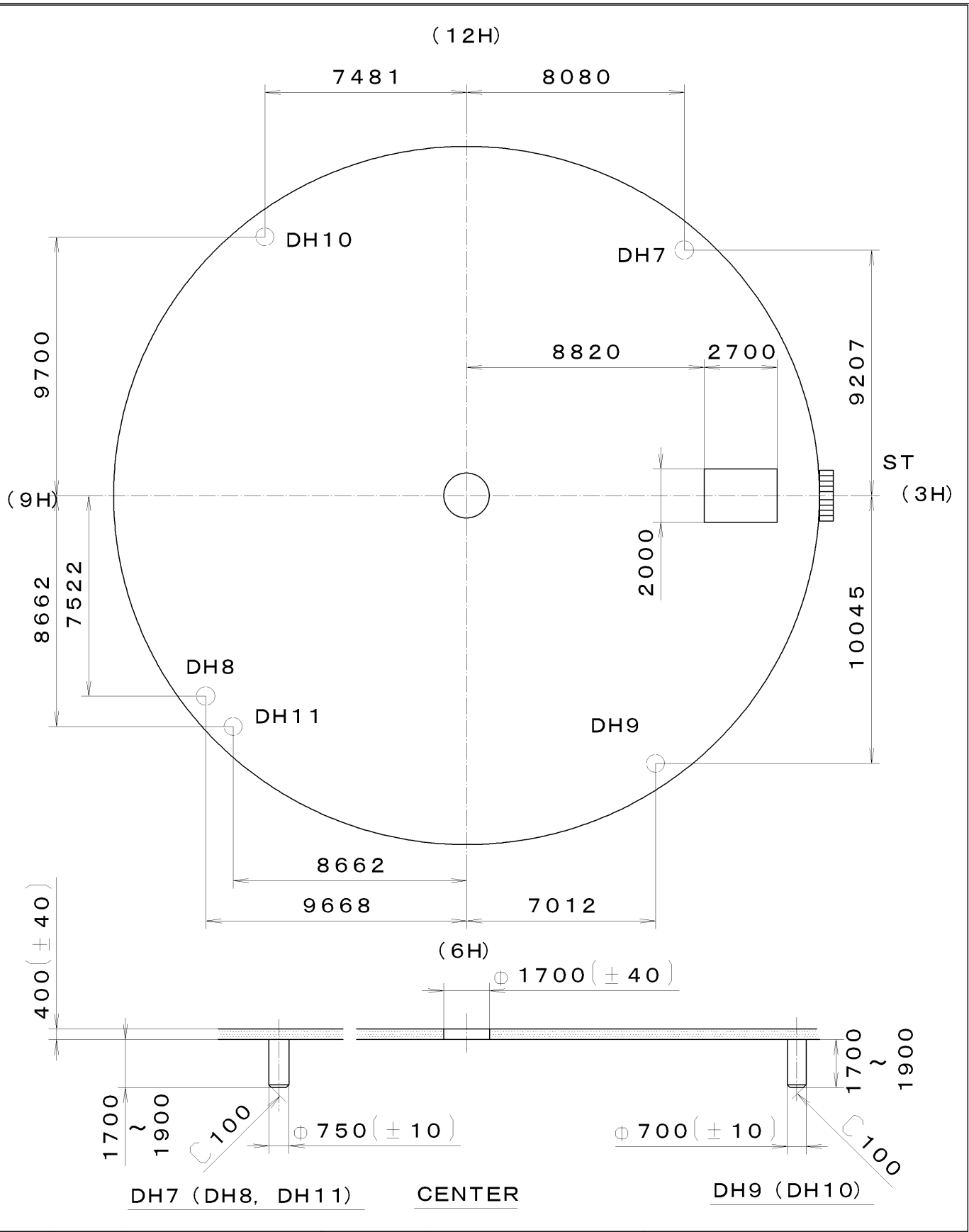

7		Quantity	Cal. No. :
6		Unit	1S13-10A
5		Scale	5:1
4		Date	Parts:
3		Drawn	Name:
2		Checked M. Fukuda	Indications for Dial
1		Approved	Drawing No. : 1S13D000
Material			
Heat Treatment		General Tolerances	
Hardness		Dimensions	
Plating		Angles	

MIYOTA

This drawing is provisional and subject to our reconfirmation and/or revision without notice.

*** T I P W 1S13-10X (01) *** (2100 1121) 03-11-06

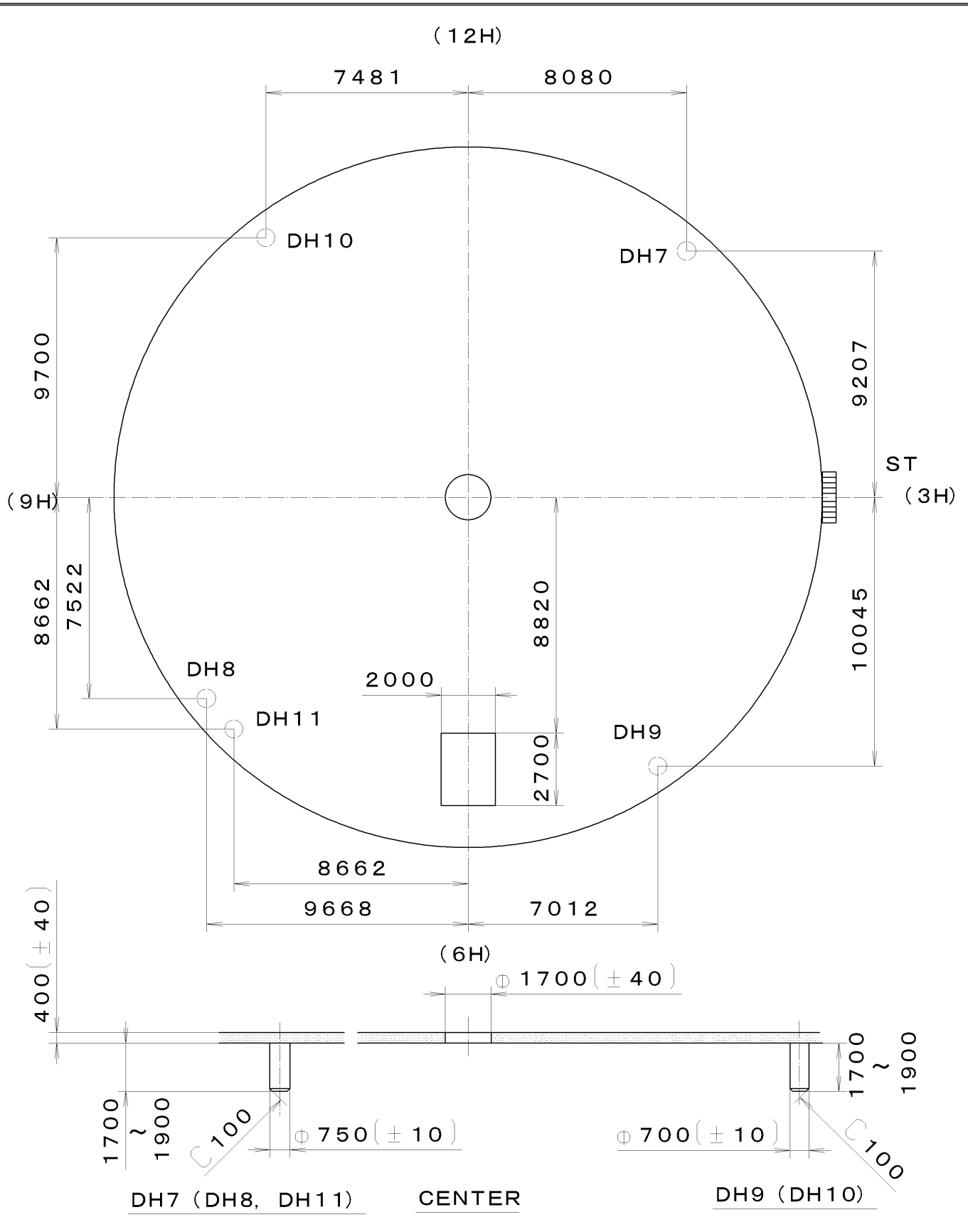

7		Quantity	Cal. No. :
6		Unit	1S13-10X
5		Scale	5:1
4		Date	Parts:
3		Drawn	Name:
2		Checked M. Fukuda	Indications for Dial
1		Approved	Drawing No. : 1S13D010
Material			
Heat Treatment		General Tolerances	
Hardness		Dimensions	
Plating		Angles	

MIYOTA

2006/12/25 (07:50:10)

This drawing is provisional and subject to our reconfirmation and/or revision without notice.

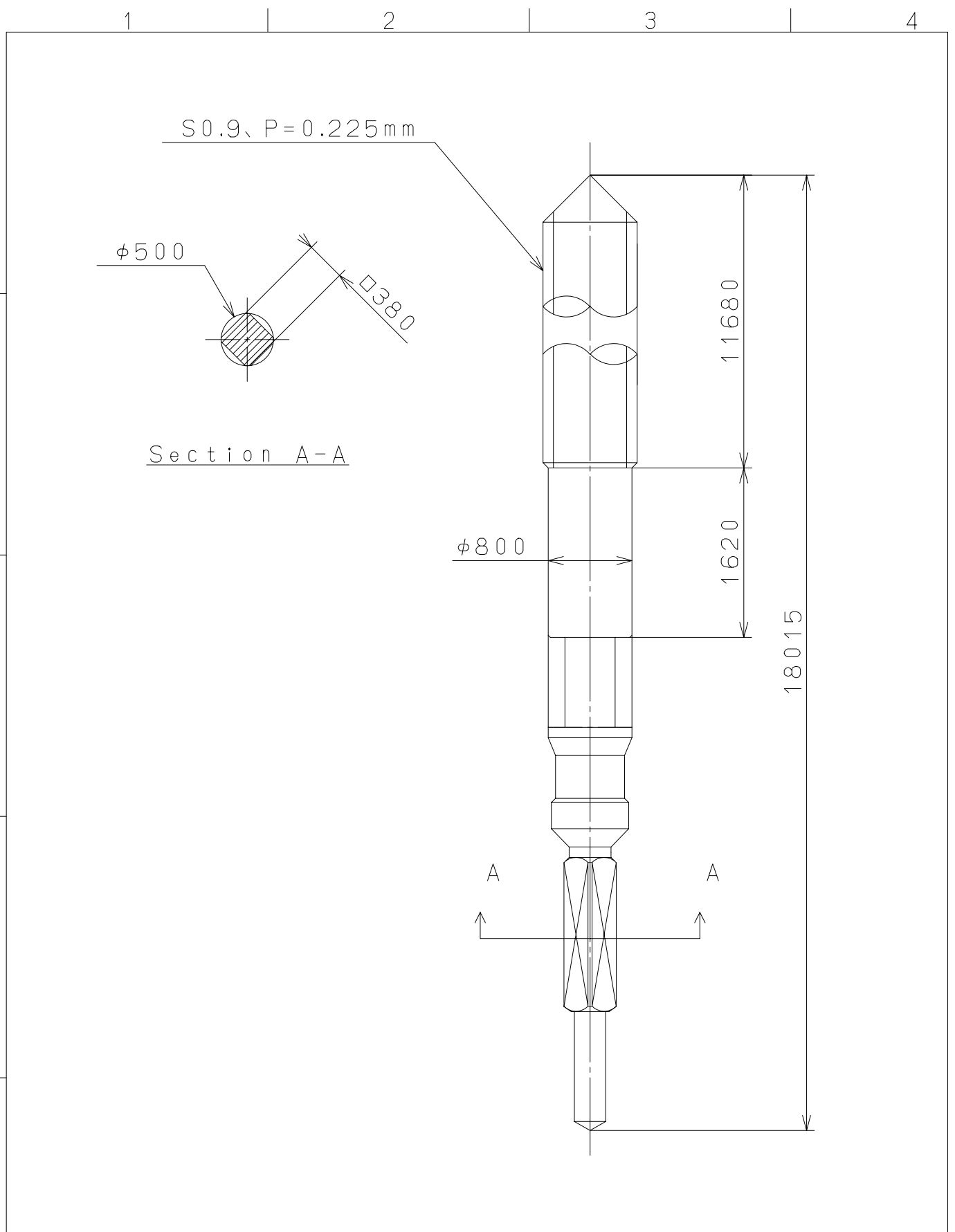

⑤			Quantity		Cal.NO.:
④			Unit	1 / 1000 mm	
③			Scale	20 / 1	Parts No.:
②			Date		065-505
①			Drawn		Name:
Mark	Date	Description	Appr.	Checked	T.Hiruta
Alterations			Approved	SETTING STEM	
Material					Drawing No.: 5050S000
Heat Treatment					MIYOTA CITIZEN WATCH CO., LTD. TOKYO, JAPAN
Hardness					
Plating					