

Watch Movement Specification and Drawing

STANDARD

# Cal. Y120E

Movement Size

**6 3/4 × 8'''**

Casing Diameter

**15.3 × 17.8 mm**

Height

**2.99mm**

Battery Life

**2 years**

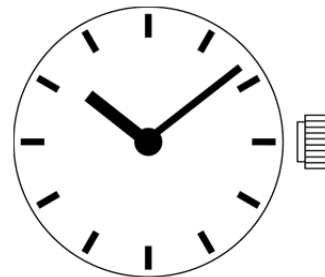

Date: 7/Apr./'17

# Cal. Y120E

Items	Rev.	Page
Specifications	03	1
Appearance	06	2
Casing	03	3
Hand fitting	04	4
Hand setting stem	05	5
Dial	03	6
Casing ring	02	7

**Analog Quartz 6 3/4 × 8<sup>mm</sup> Standard Series Movement / Two Hands (H/M)****1. MOVEMENT DIMENSIONS**

Outside diameter	15.30mm(3-9H) × 18.20mm(12-6H)
Casing diameter	15.30mm(3-9H) × 17.80mm(12-6H)
Total height	2.99mm

**2. TIME STANDARD**

Type of quartz oscillator	Tuning fork
Frequency of quartz oscillator	32,768 Hz
Accuracy	±20 seconds per month (on wrist)
Operating temperature range	-5°C to +50°C
Regulation device	Nil (Pre-adjusted)

**3. INDICATOR / FUNCTIONS**

2 Hands	Hour / Minute
Reset switch	
Setting mechanism	Crown at normal position : Free Crown pulled out 1st click : Time setting / Reset

**4. FEATURES**

Jewels	0 Jewels
Anti-magnetism	Over 1600A/m (Direct current magnetic field)
Maximum unbalance of hands	Minute hand : 0.6 μ N·m Hour hand : 0.5 μ N·m

**5. BATTERY**

Type / Size	Silver oxide battery / φ 6.8mm × t 2.6mm
Recommended battery	SR626SW (Maxell, Sony, Seizaiken)
Nominal voltage	1.55 V
Battery life	Approx. 2 years
Driving current consumption	Approx. 1.5 μ A
Operation stopping voltage	1.1 V

**6. SEPARATED PARTS (Parts code)**

Hand setting stem	0354788 or 0354787
Battery	SR626SW

**7. TEST OF ACCURACY**

Equipment to be used	SEIKO quartz tester QT-99, Greiner quartz timer-C , Witschi Q-tester 4000
Duration of measurement	10 seconds
Microphone to be used	Electromagnetic detection type

All specifications are subject to change without notice.

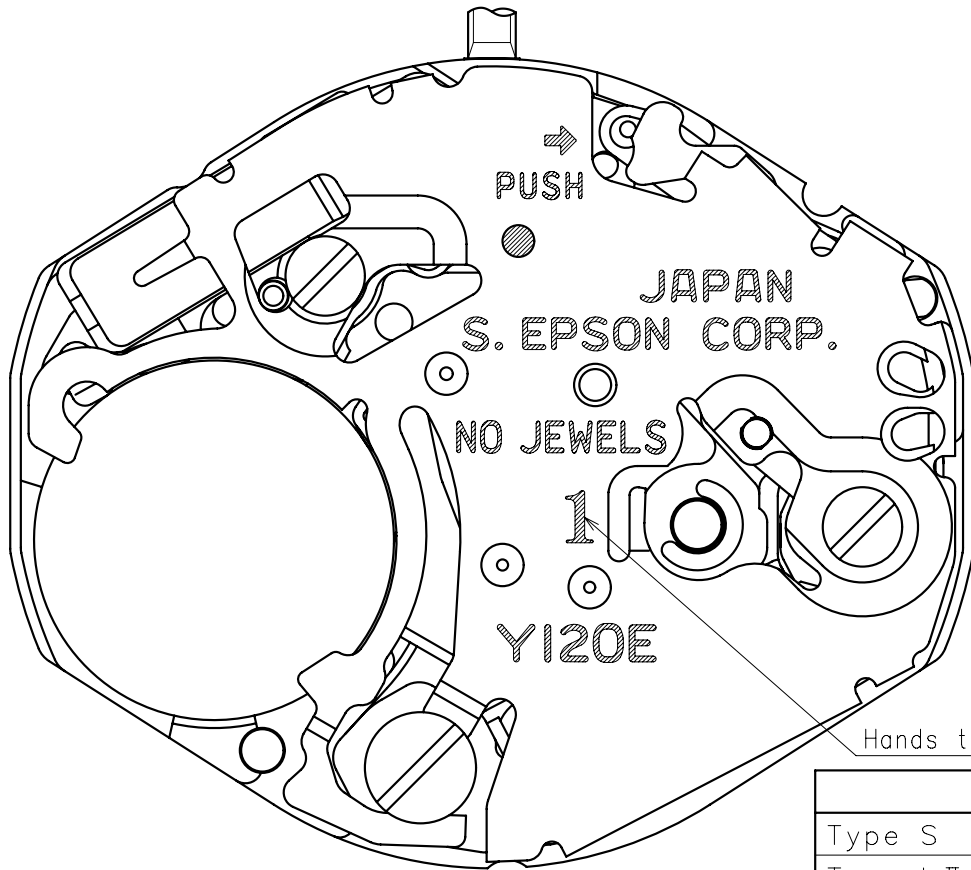

	Mark
Type S (1)	1
Type LII (4)	4

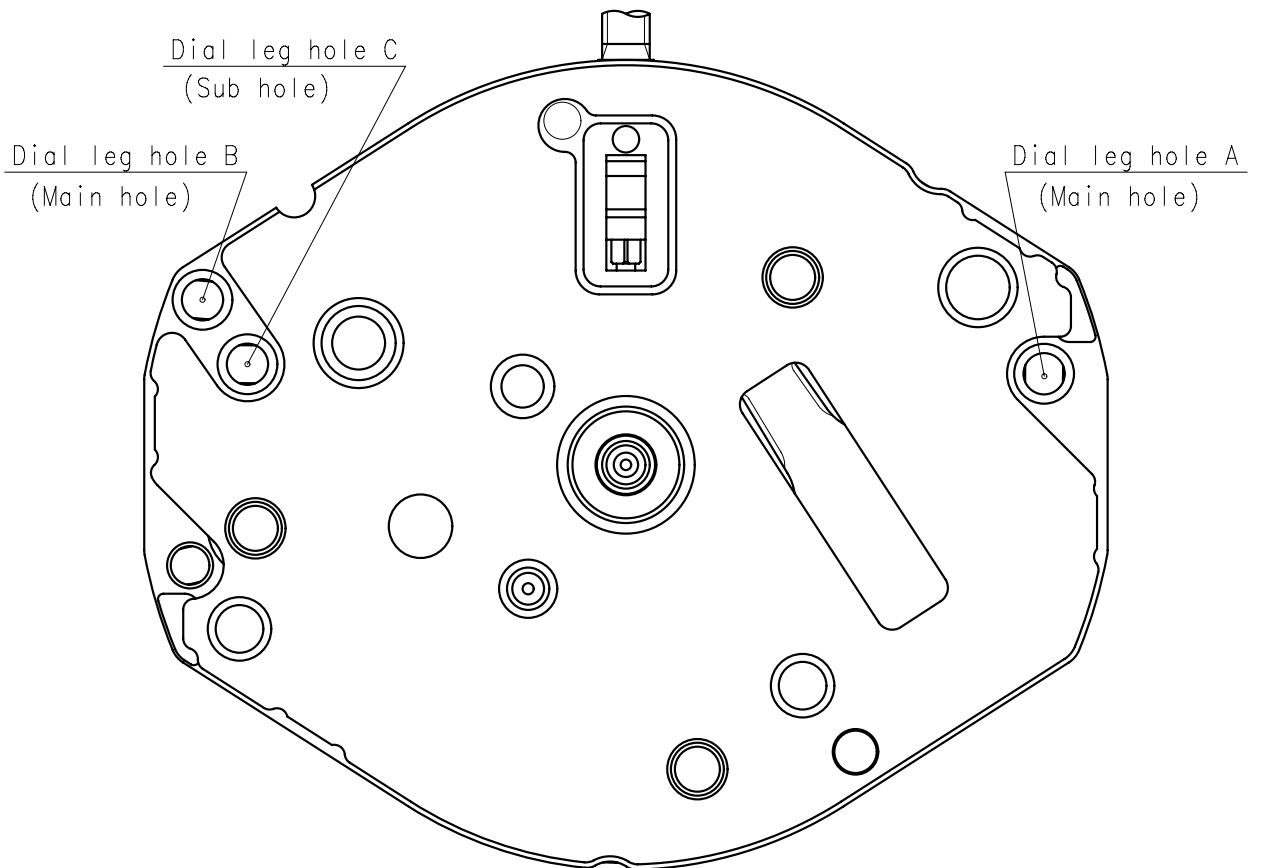

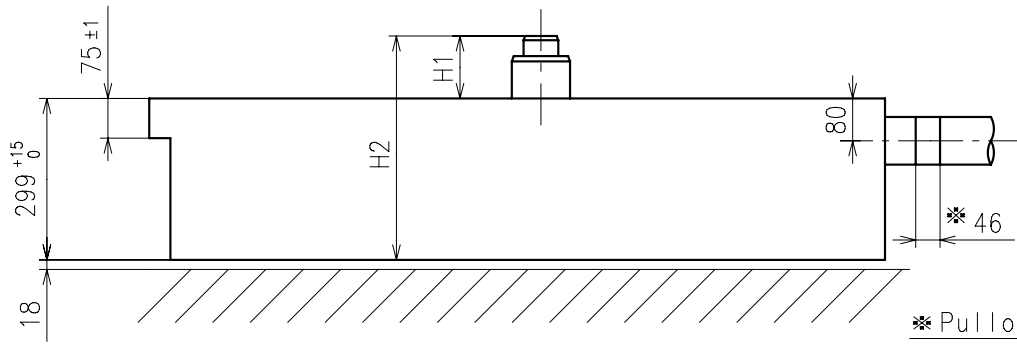

\* Pullout stroke

Center post		Type S (1) Y120E1	Type LI(4) Y120E2
Maximum height from dial support	H1	118	226
Total height including movement	H2	423	531

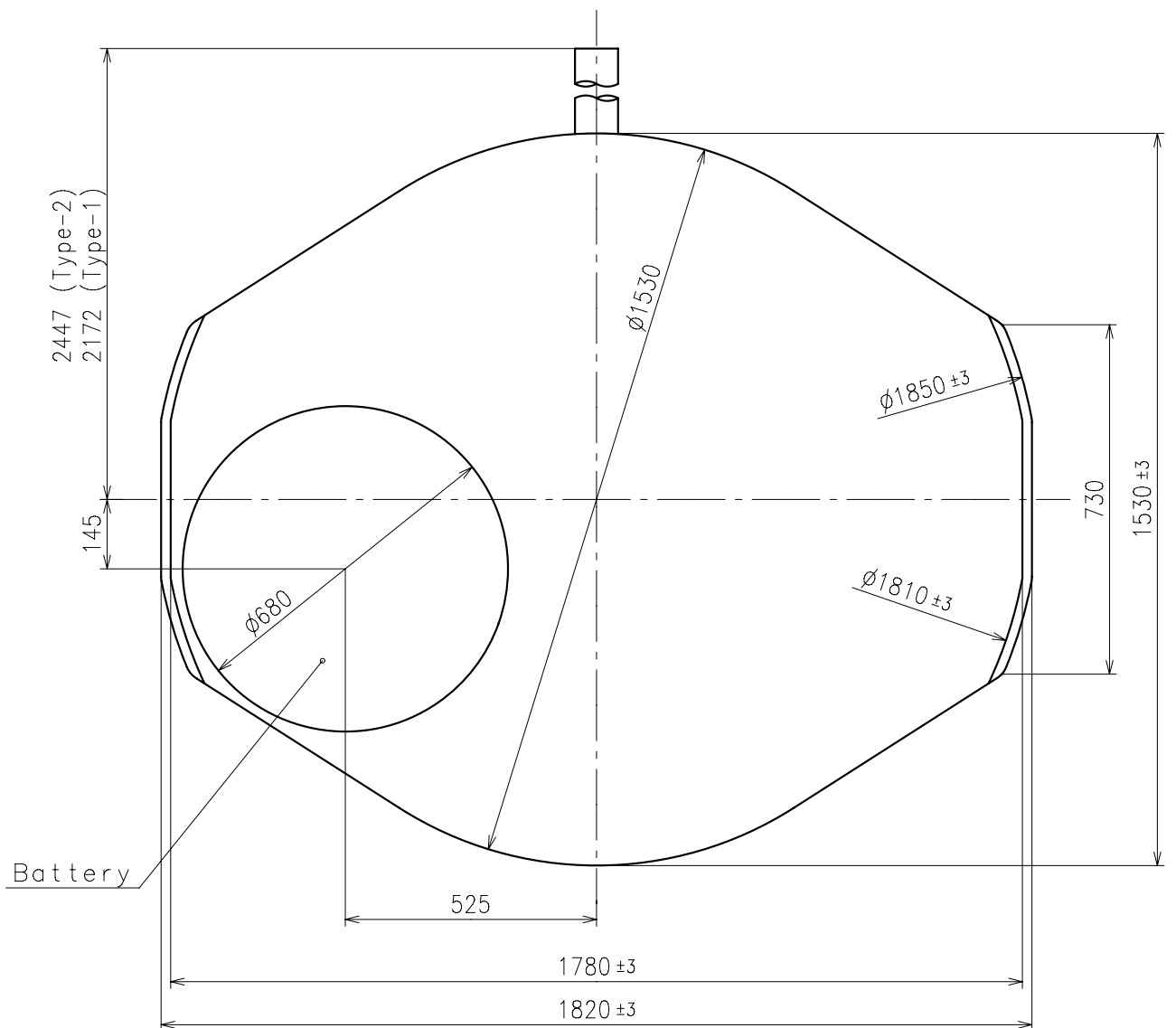

- \* Minute hand unbalance  $\leq 0.6\mu \text{ N}\cdot\text{m}$  ( $60\mu \text{ g}\cdot\text{m}$ )
- \* Hour hand unbalance  $\leq 0.5\mu \text{ N}\cdot\text{m}$  ( $50\mu \text{ g}\cdot\text{m}$ )

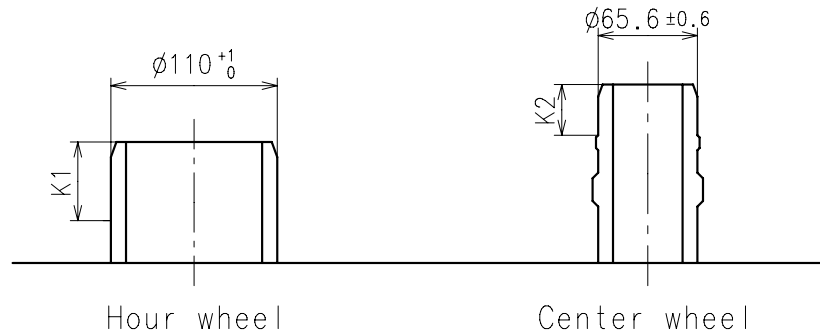

	Parts No.		Dimension	
	Hour wheel	Center wheel	K1	K2
Type S (1) Y120E1	0271796	0221797	52	33.5
Type LII(4) Y120E2	0271797	0221779	60	33.5

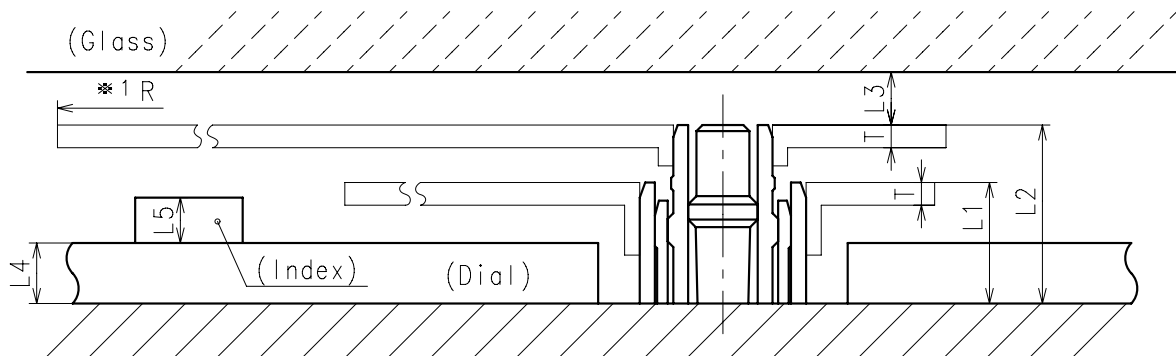

	L1	L2	L3	L4	L5	T	*1 R
Type S (1) Y120E1	80	118	MIN: 35	40	MAX: 30	15	MAX: 1250
Type LII(4) Y120E2	185	226	MIN: 35	MAX: 150	MAX: 30	15	MAX: 1250

\*1: It is the size taken into consideration for hands attachment.  
Please observe some standard value specified in unbalance when using long hands.

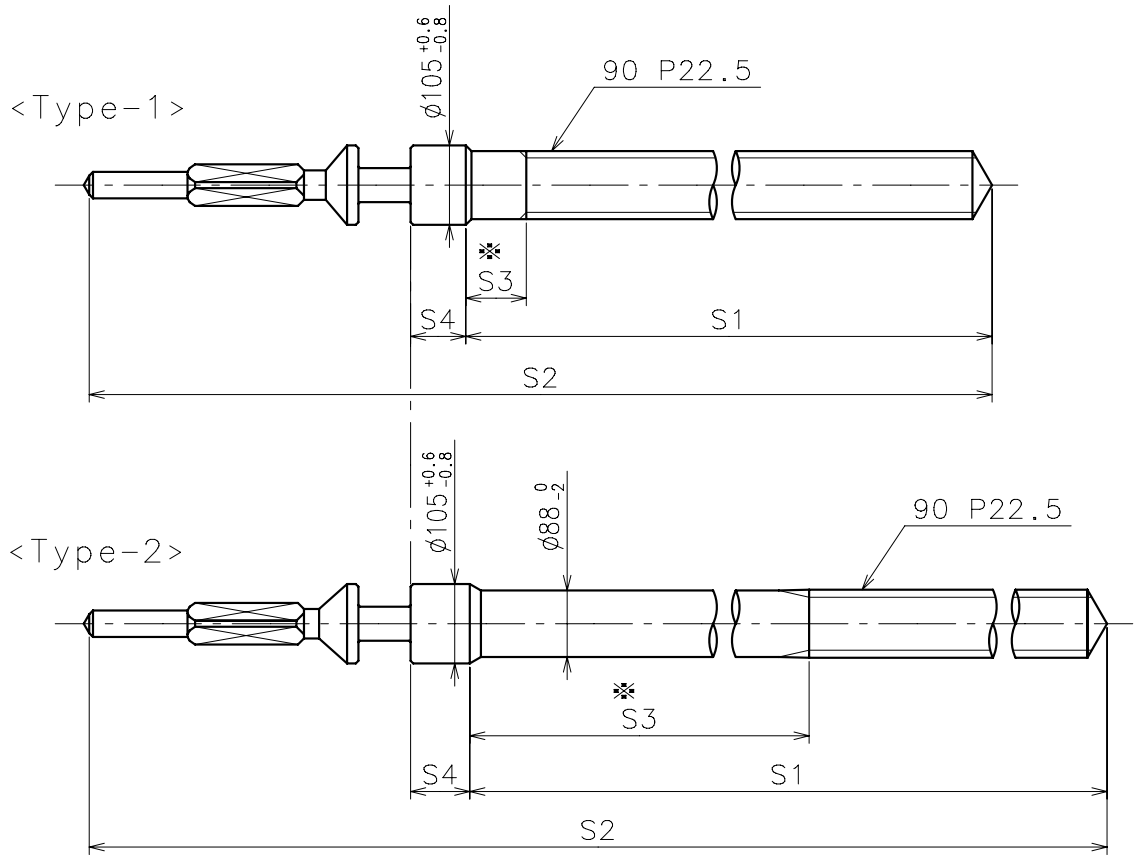

\* Not threaded

	Part No.	S1	S2	* S3	S4
Type-1 (Standard)	0354788	1473	1971	80	73
Type-2	0354787	1743	2246	887	78

Material : Steel

Hardness : Vickers 530±50

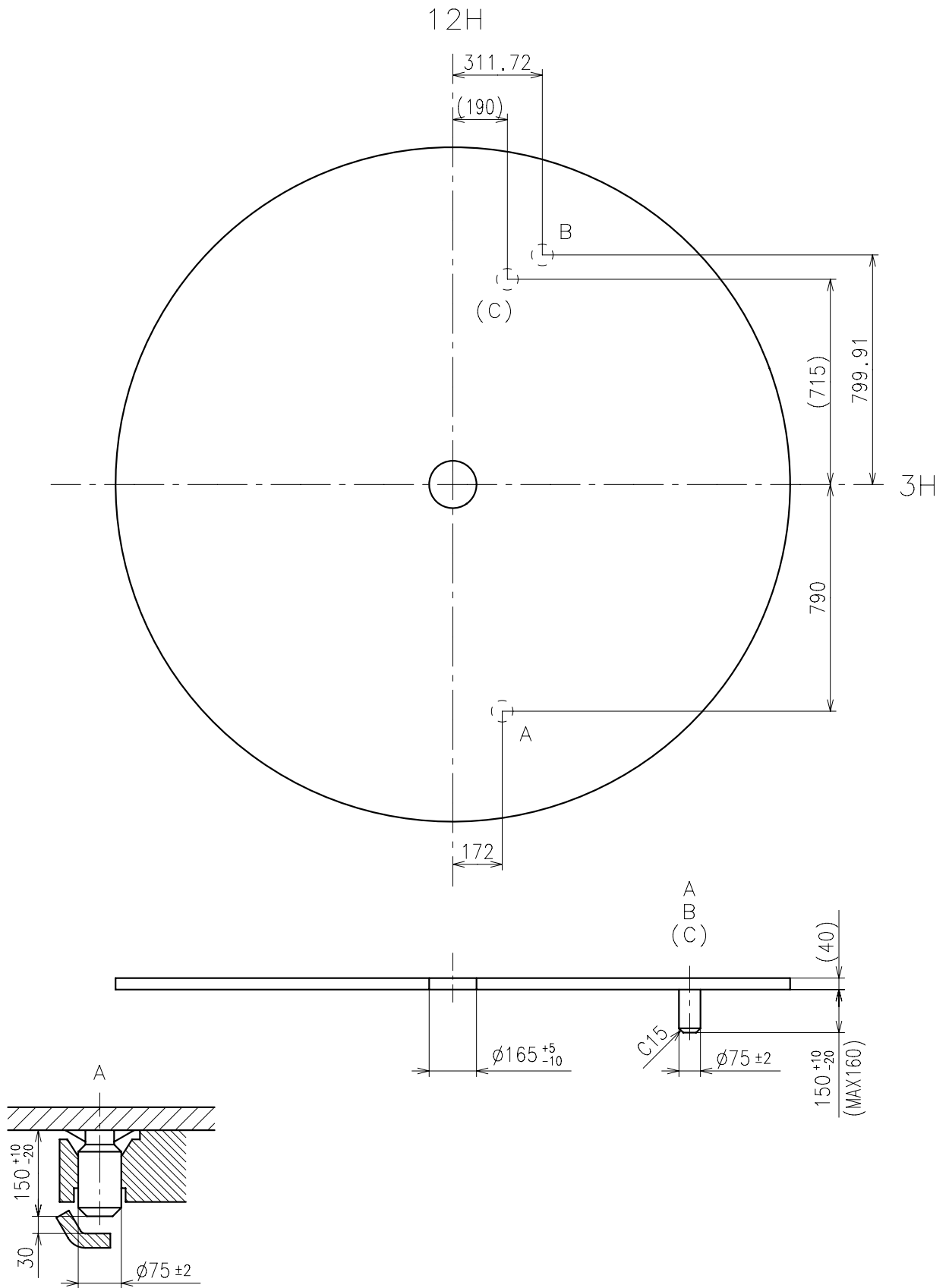

Use dial leg A-B(Main) or A-C(Sub)



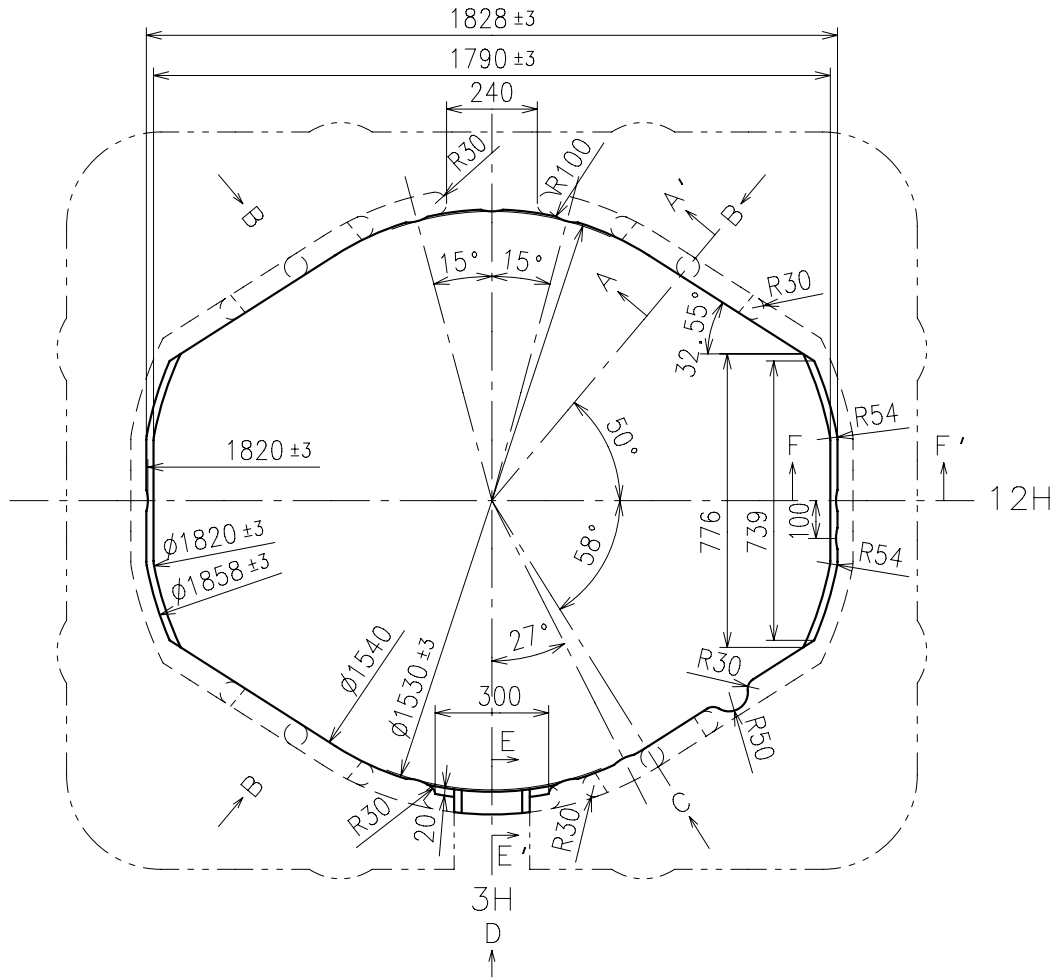

A-A' section

E-E' section

D view

F-F' section

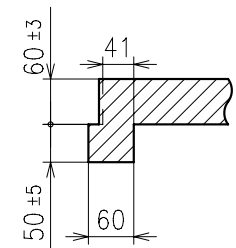
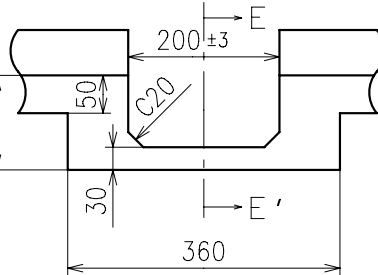
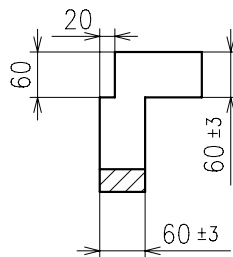
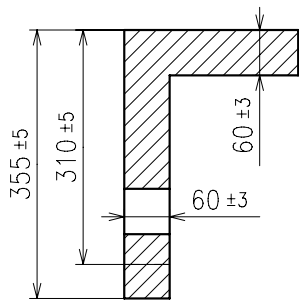

B view

C view

