

Watch Movement Specification and Drawing

## CHRONOGRAPH

# Cal. VR3GA

Movement Size

13 1/2'''

Casing Diameter

Ø 30.6mm

Height

3.97mm

Battery Life

3 years

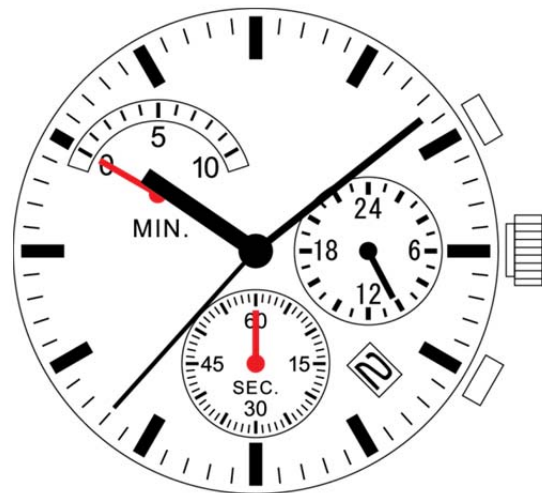

Date: 30/Nov./17

# Cal. VR3GA

Items	Rev.	Page
Specifications	00	1
Appearance	01	2
Casing	03	3
Hand fitting	02	4
Hand setting stem	01	5
Dial-1	00	6-01
Dial-2	00	6-02
Casing ring	00	7
Operation	00	8
Attention-1	00	9-01
Attention-2	00	9-02

Cal. VR3GA	<h1>Specifications</h1>	Date : 30/Jan./15
		Rev. : 00
<b>Analog Quartz 13 1/2" Chronograph Movement</b>		
<b>1. MOVEMENT DIMENSIONS</b>		
Outside diameter	φ 31.2mm × 28.0mm(3-9H)	
Casing diameter	φ 30.6mm	
Total height	3.97mm (including battery)	
<b>2. TIME STANDARD</b>		
Type of quartz oscillator	Tuning fork	
Frequency of quartz oscillator	32,768 Hz	
Accuracy	±20 seconds per month (on wrist)	
Operating temperature range	-5°C to +50°C	
Regulation device	Nil (Pre-adjusted)	
<b>3. INDICATOR / FUNCTIONS</b>		
3 Hands	Hour / Minute / Second	
Small hands	24 hour(3H) / Second chronograph(6H) / Minute chronograph(10H)	
Calendar	Instant setting device for date calendar	
Reset switch		
Power depletion warning function (BLD)		
(Second hand moves at 2-second intervals)		
Setting mechanism	Crown at normal position	: Free
	Crown pulled out 1st click	: Instant date change
	Crown pulled out 2nd click	: time setting / reset
Chronograph	1/1 second up to 10 minutes with split time measurement	
<b>4. FEATURES</b>		
Jewels	0 Jewels	
Anti-magnetism	Over 1600A/m (Direct current magnetic field)	
Maximum unbalance of hands	Hour hand	: 0.6 μ N·m
	Minute hand	: 0.9 μ N·m
	Second hand	: 0.09 μ N·m
	24 hour hand	: 0.05 μ N·m
	Second chronograph hand	: 0.05 μ N·m
	Minute chronograph hand	: 0.05 μ N·m
Moment of Inertia	Second hand	: less than 0.35 μ g·m <sup>2</sup>
	Second chronograph hand	: less than 0.05 μ g·m <sup>2</sup>
<b>5. BATTERY</b>		
Type / Size	Silver oxide battery / φ9.5mm × t2.0mm	
Recommended battery	SR920SW (Maxell, Sony, Seizaiken)	
Nominal voltage	1.55 V	
Battery life	Approx. 3 years	
Driving current consumption	Approx. 1.2 μ A	
Operation stopping voltage	1.4V (Chronograph function)	
<b>6. SEPARATED PARTS (Parts code)</b>		
Hand setting stem	0351578 or 0351177	
Battery	SR920SW	
<b>7. TEST OF ACCURACY</b>		
Equipment to be used	SEIKO quartz tester QT-99, Greiner quartz timer-C , Witschi Q-tester 4000	
Duration of measurement	10 seconds	
Microphone to be used	Electromagnetic detection type	
All specifications are subject to change without notice.		

Hands type

	Mark
Type M	2
Type L	3

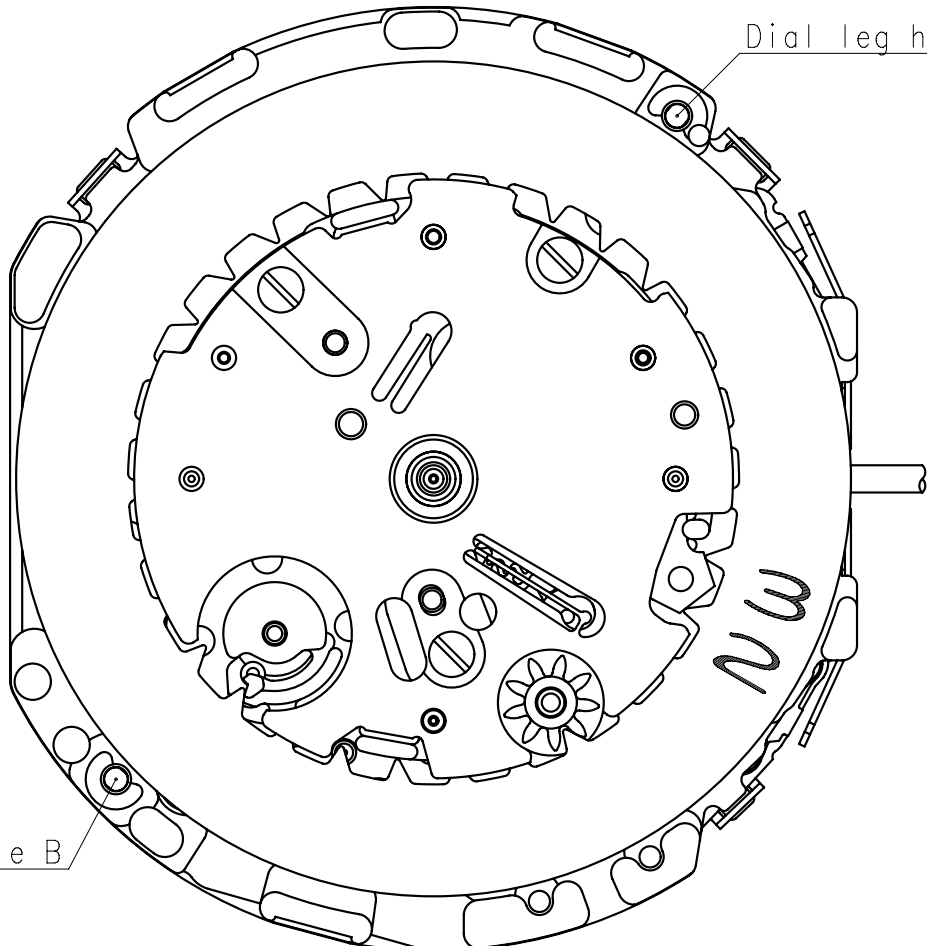
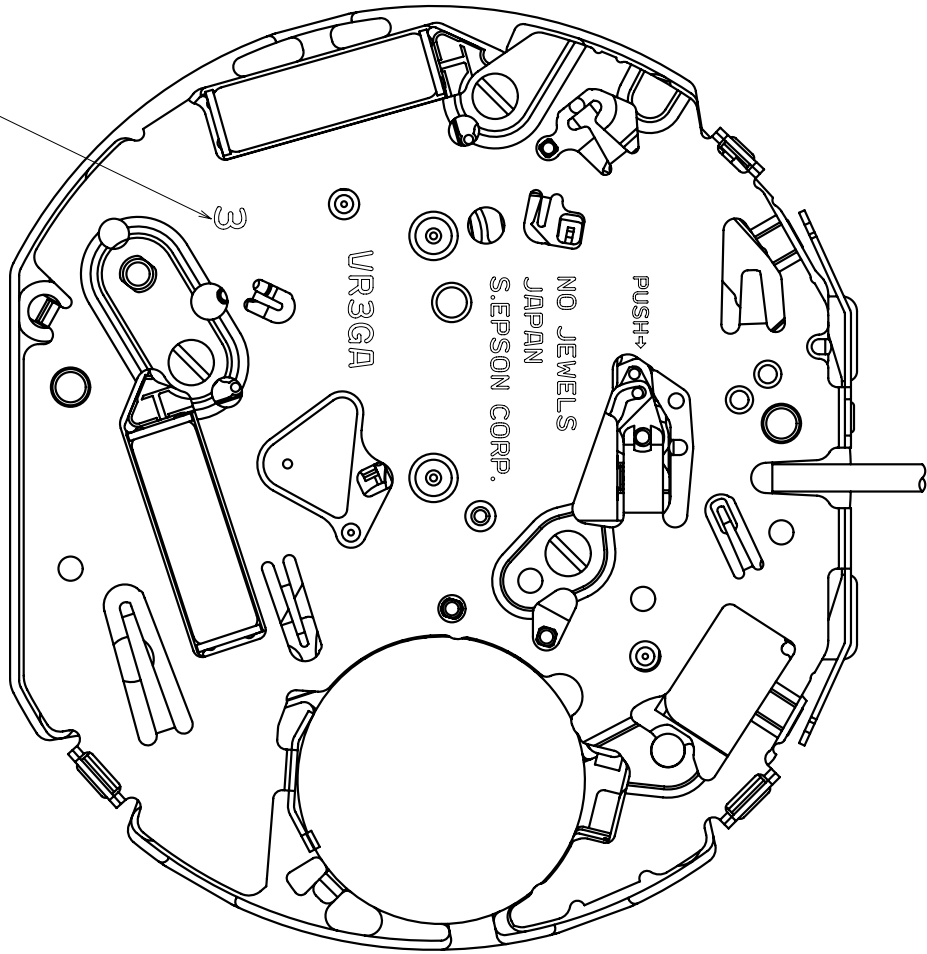

Dial leg hole B

Dial leg hole A

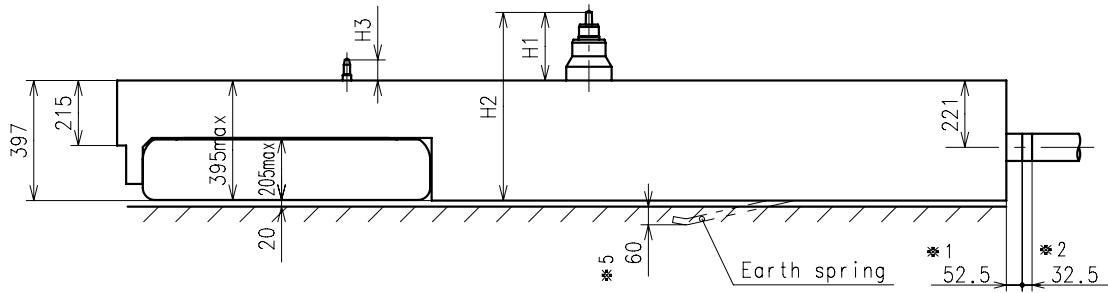

Center post		Type M (2) VR3GA**	Type L (3) VR3GA**
Maximum height from dial support	H1	225	295
Total height including movement	H2	622	692
Maximum height from dial support	H3	70	135

- \*1: First pullout stroke
- \*2: Second pullout stroke
- \*3: Button stroke
- \*4: Switching stroke
- \*5: The earth spring is absolutely placed in contact with the case back.

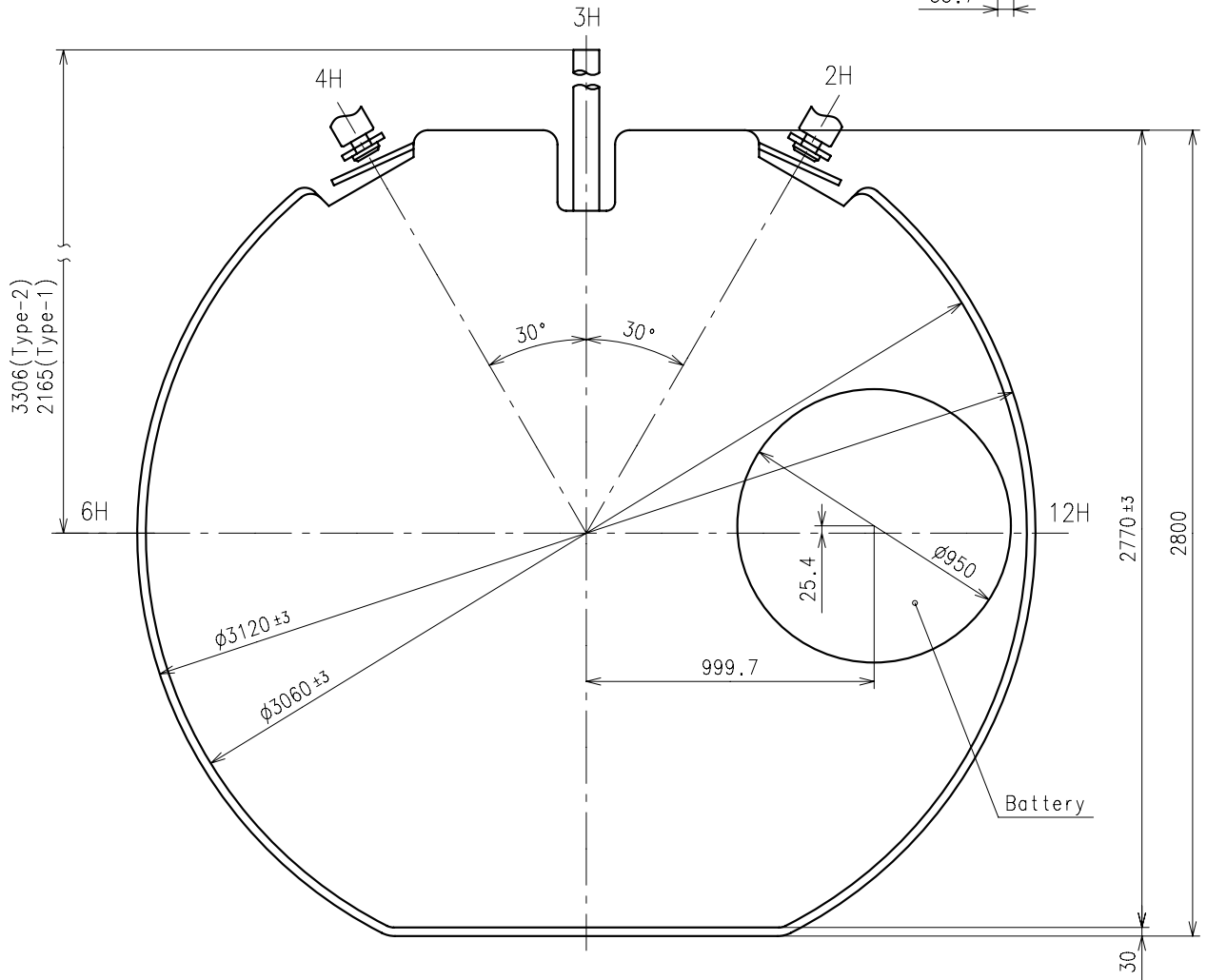
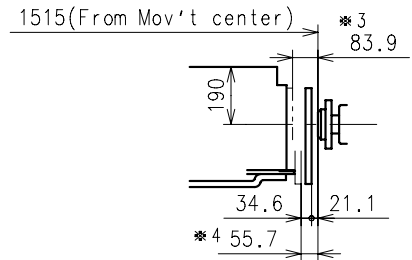

※ Unbalance

- Hour hand  $\mathbb{W}$   $0.6\mu\text{ N}\cdot\text{m}$  ( $60\mu\text{ g}\cdot\text{m}$ )
- Minute hand  $\mathbb{W}$   $0.9\mu\text{ N}\cdot\text{m}$  ( $90\mu\text{ g}\cdot\text{m}$ )
- Second hand  $\mathbb{W}$   $0.09\mu\text{ N}\cdot\text{m}$  ( $9\mu\text{ g}\cdot\text{m}$ )
- Second chronograph hand  $\mathbb{W}$   $0.05\mu\text{ N}\cdot\text{m}$  ( $5\mu\text{ g}\cdot\text{m}$ )
- Minute chronograph hand  $\mathbb{W}$   $0.05\mu\text{ N}\cdot\text{m}$  ( $5\mu\text{ g}\cdot\text{m}$ )
- 24 hour hand  $\mathbb{W}$   $0.05\mu\text{ N}\cdot\text{m}$  ( $5\mu\text{ g}\cdot\text{m}$ )

※ Moment of inertia

- Second hand  $\mathbb{W}$   $0.35\mu\text{ g}\cdot\text{m}^2$
- Second chronograph hand  $\mathbb{W}$   $0.05\mu\text{ g}\cdot\text{m}^2$

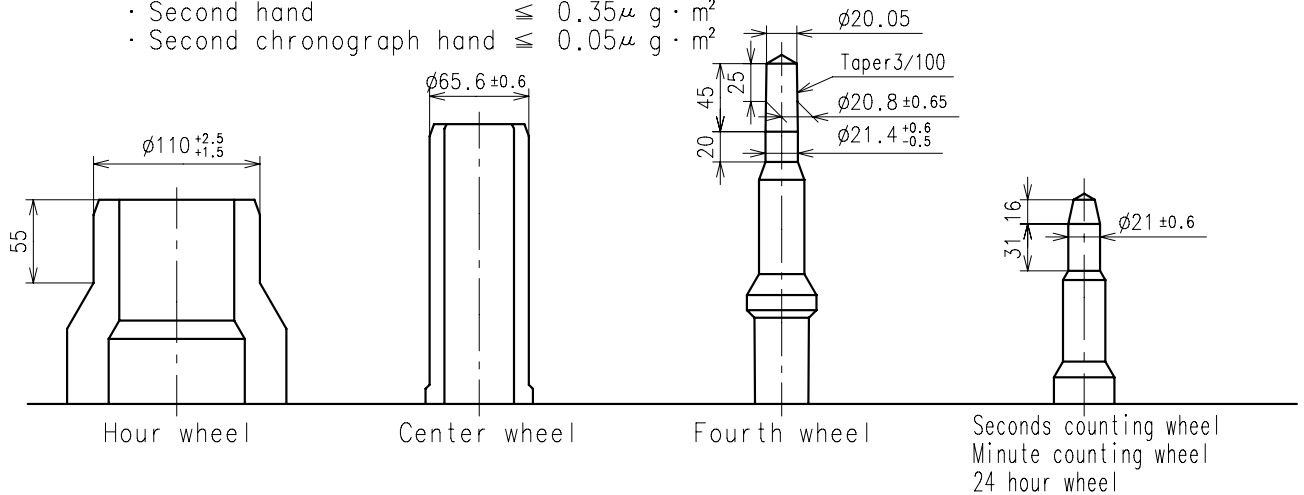

	Parts No.					
	Hour wheel	Center wheel	Fourth wheel	Seconds counting wheel	Minute counting wheel	24 hour wheel
Type M(2) VR3GA**	0271661	0221662	0241592	0888510	0888520	1002561
Type L(3) VR3GA**	0271662	0221663	0241593	0888511	0888521	1002562

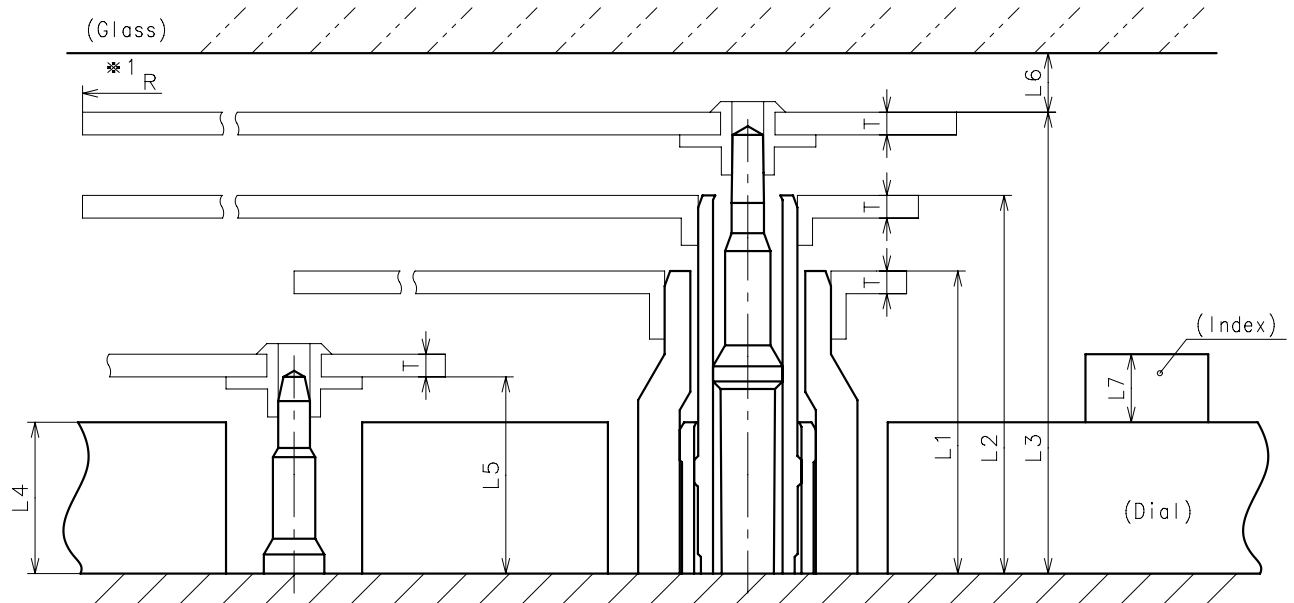

	L1	L2	L3	L4	L5	L6	L7	T	*1 R
Type M(2) VR3GA**	135	185	240	40	70	MIN: 50	MAX: 50	15	MAX: 1500
Type L(3) VR3GA**	205	255	310	105	135	MIN: 50	MAX: 50	15	MAX: 1500

※ 1: It is the size taken into consideration for hands attachment.  
Please observe some standard value specified in unbalance and moment of inertia when using long hands.

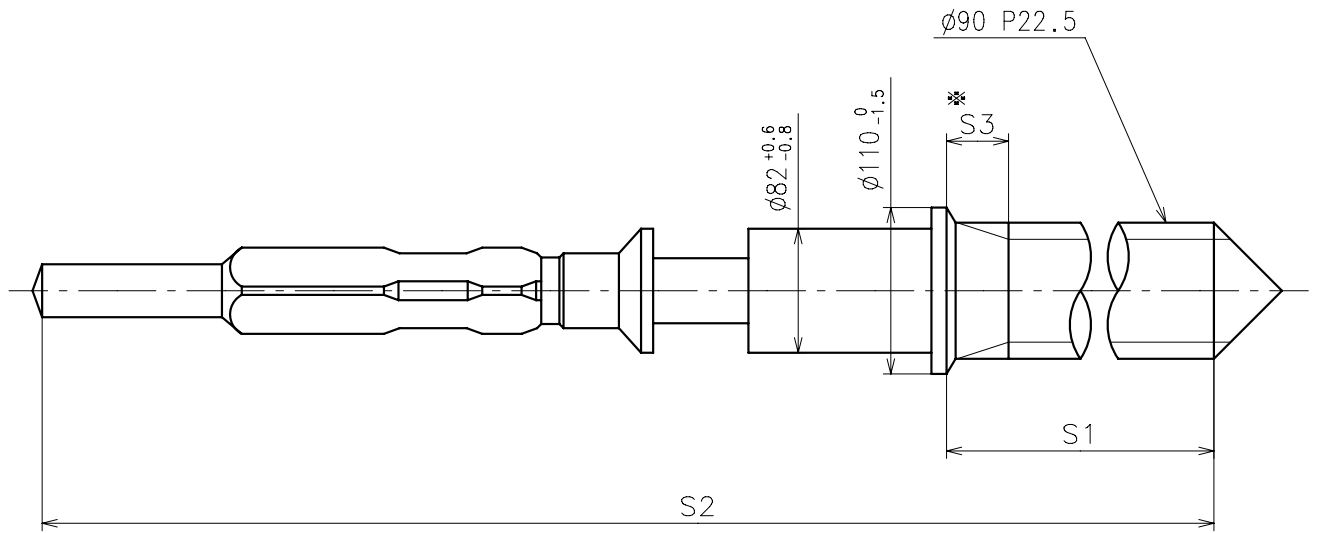

\* Not threaded

	Part No.	S1	S2	* S3
Type-1	0351177	1366	1964	60
Type-2 (Standard)	0351578	2507	3105	650

Material : Steel

Hardness : Vickers 600±50

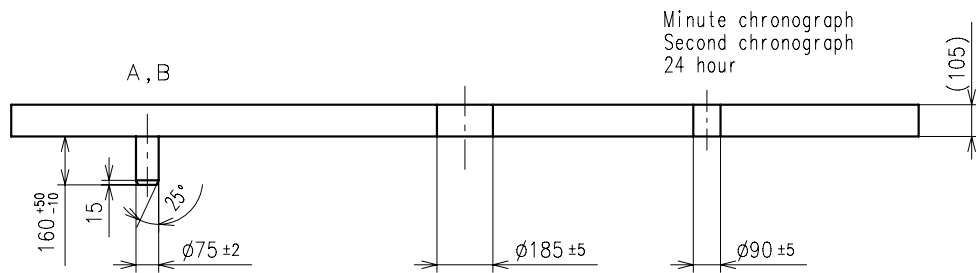
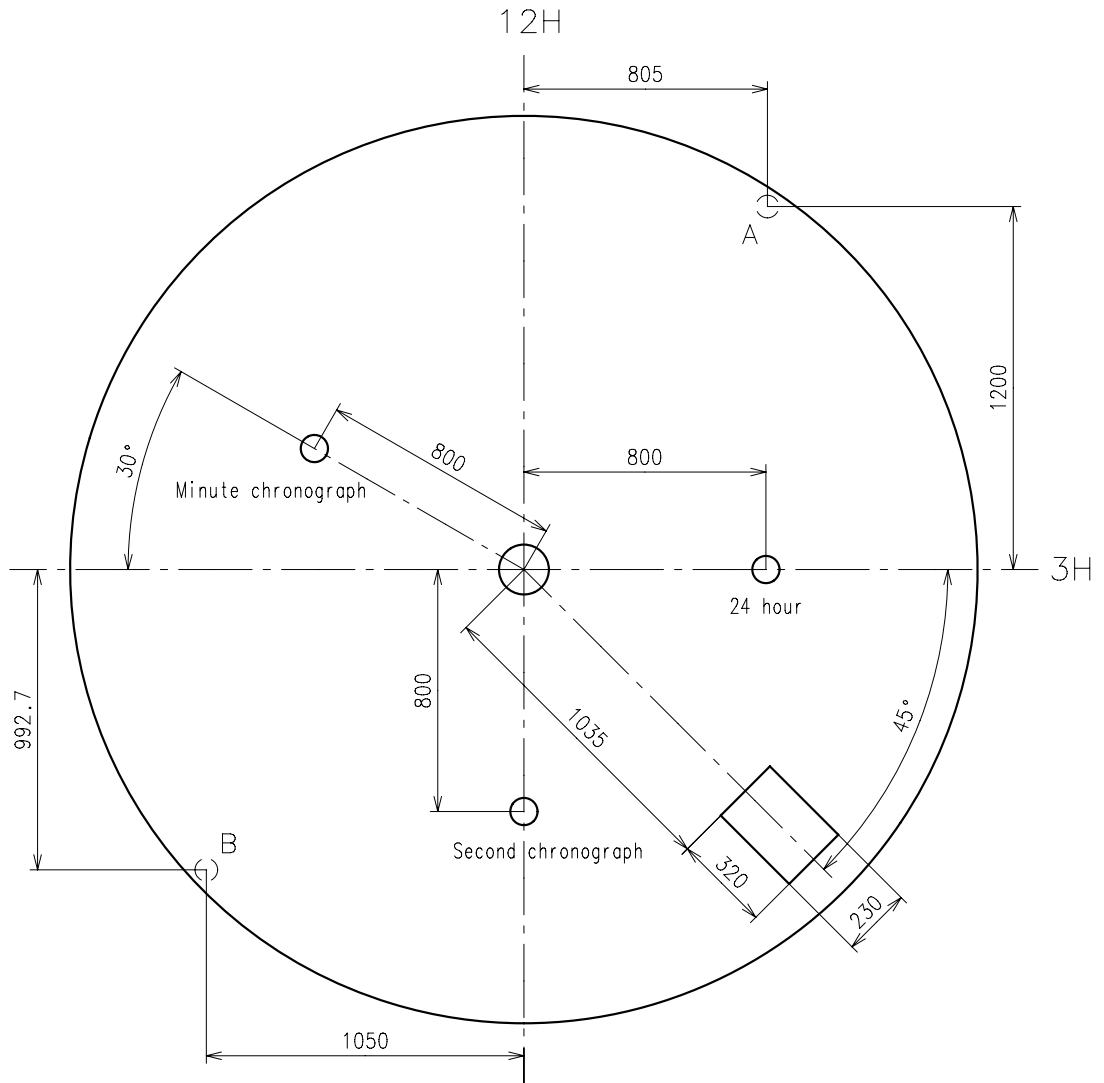

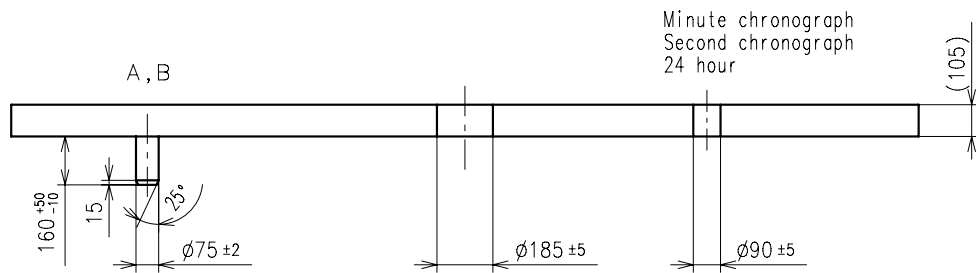
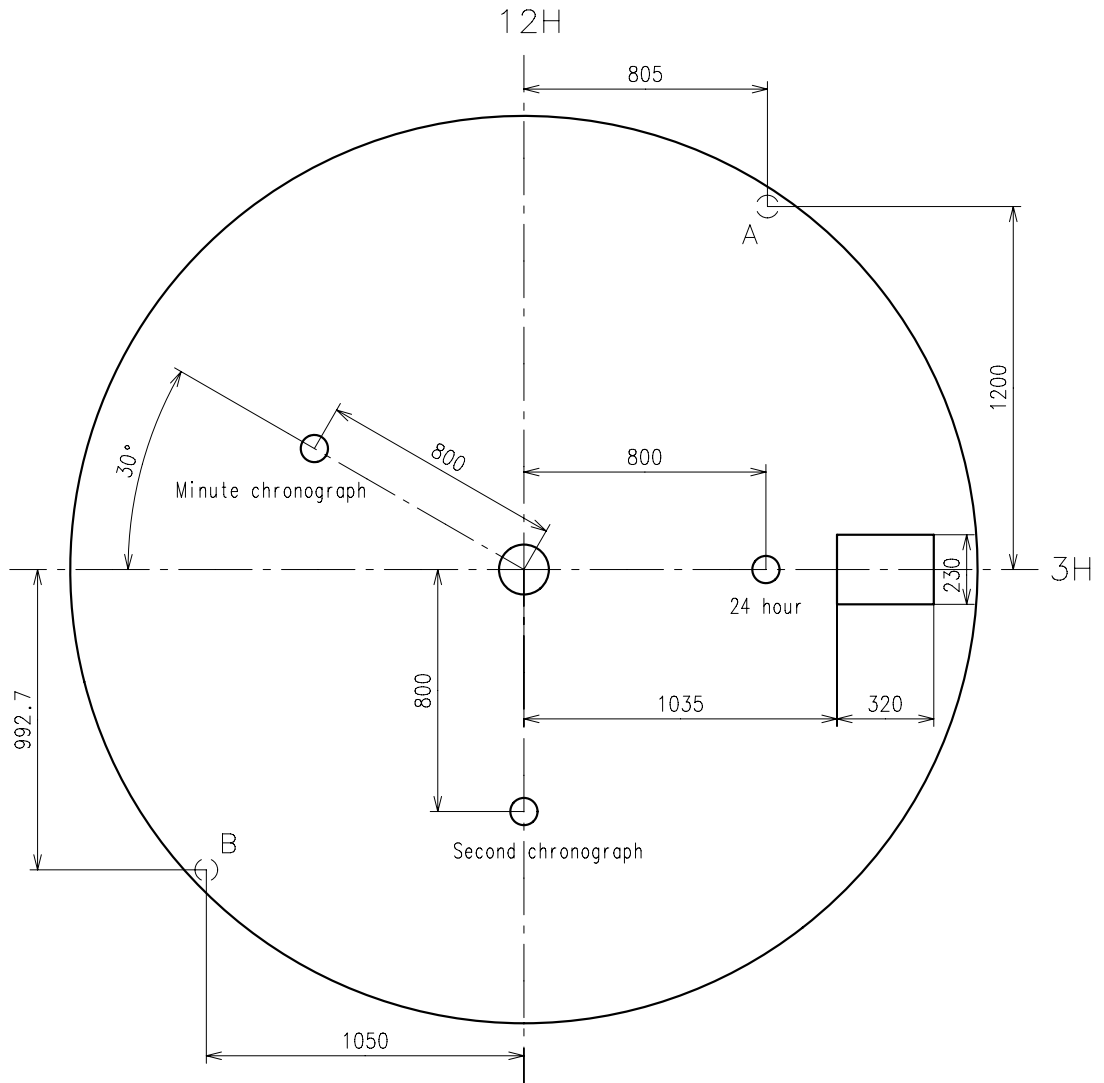

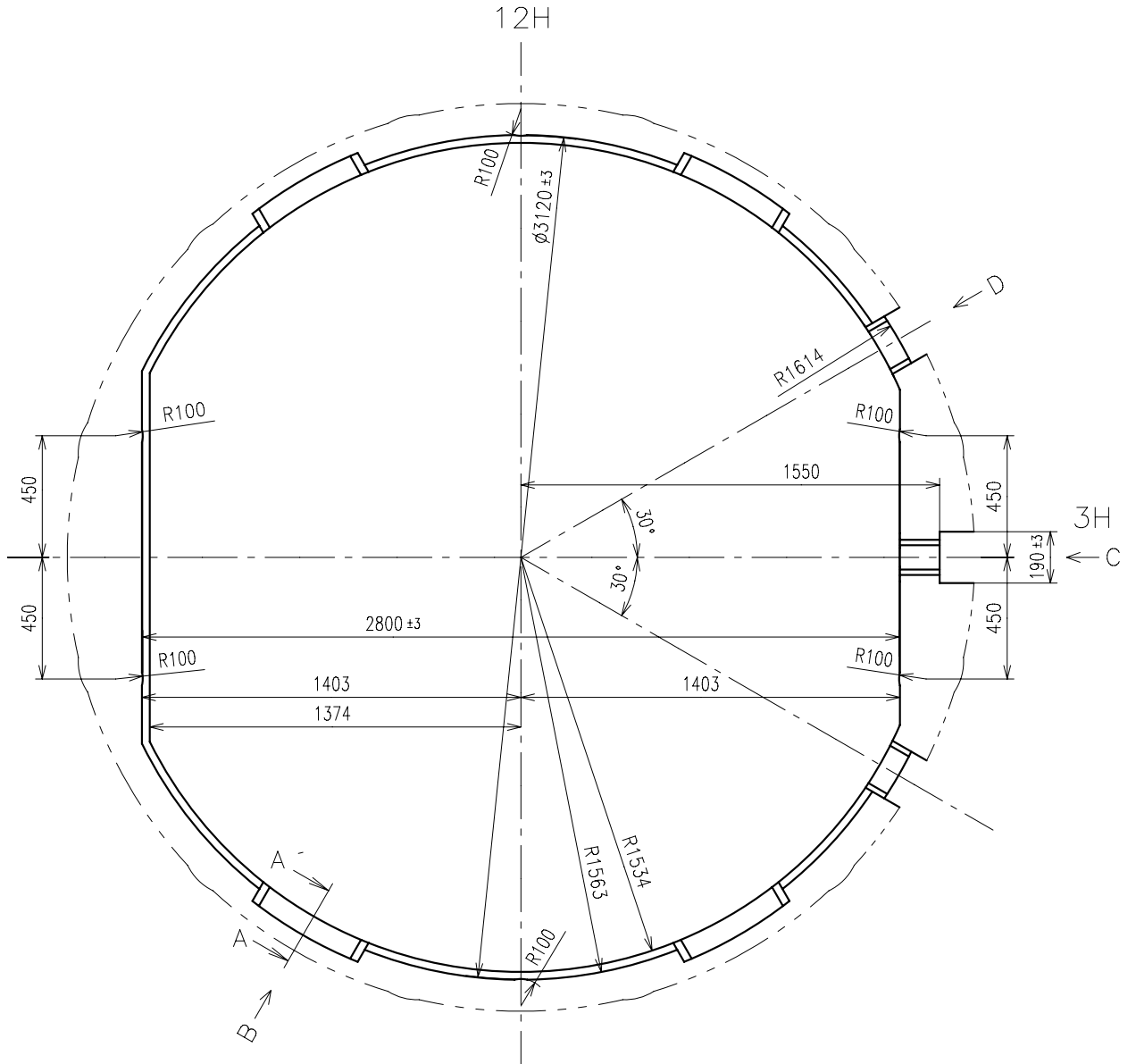

A-A section

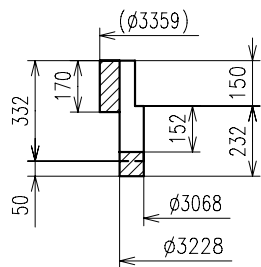

B view

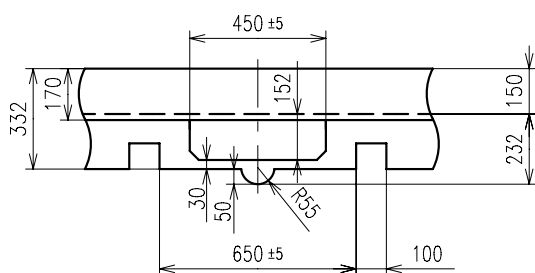

C view

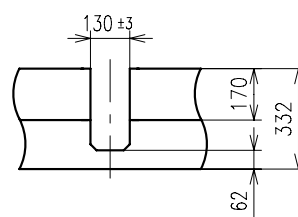

D view

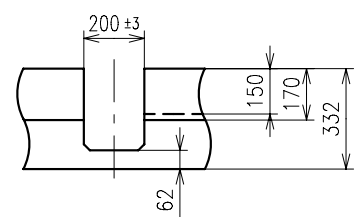

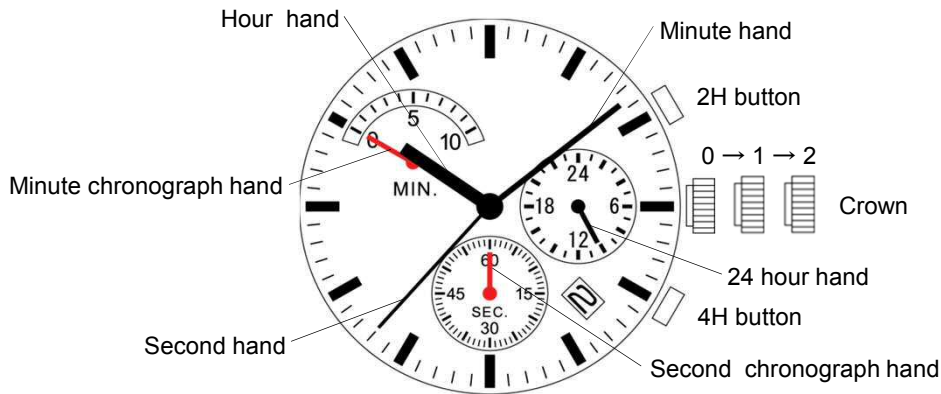

	Crown position		
	0 click	1st click	2nd click
Crown	Free	Turn counterclockwise for date change	Time setting
2H button	Chronograph Start/Stop Restart	Chronograph Start/Stop Restart	Chronograph hands 0-setting (clockwise)
4H button	Chronograph Reset Split Split release	Chronograph Reset Split Split release	Chronograph hands 0-setting (counterclockwise)

**Chronograph function**

Second chronograph hand is capable of timing 10 minutes. (60 seconds x 10 times)  
Minute chronograph hand is capable of timing 10 minutes.

■ Standard measurement

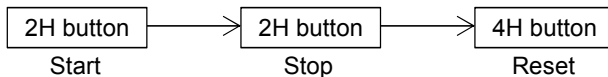

■ Accumulated elapsed time measurement

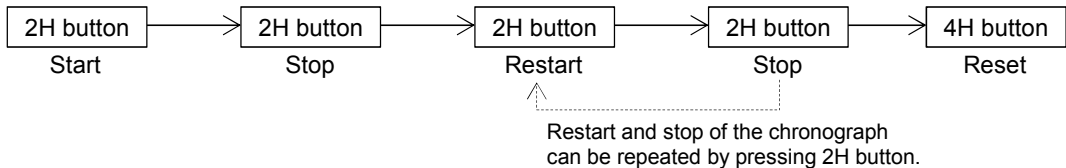

■ Split time measurement

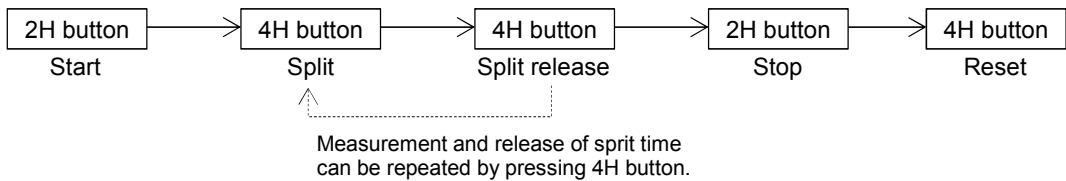

■ Measurement of two competitors

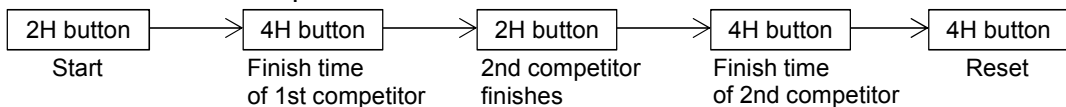

**1. Case**

Please use the metal case back to prevent from the movement mal-function by static electricity.

**2.Hour Wheel**

When set and remove the hour hand repeatedly, it may reduce the hand fixing torque because the hour wheel is made by plastic.

To ensure the enough fixing torque, it isn't recommended to re-assemble the hour hand more than five times.

**3. Button position**

Please keep the clearance between the movement and the tip of button to prevent the interference in assembling and enable to be cased smoothly.

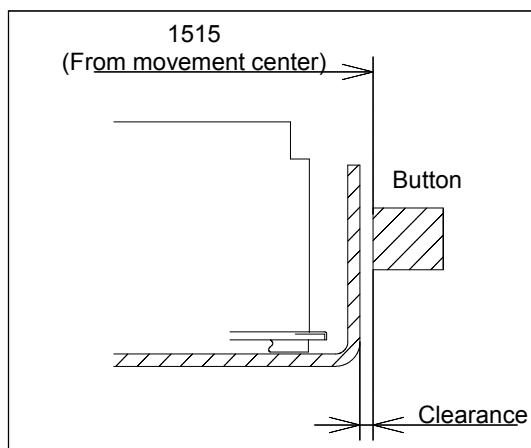

To keep the clearance, it is recommended to use button spring.

**1.The index design instruction of chronograph hand**

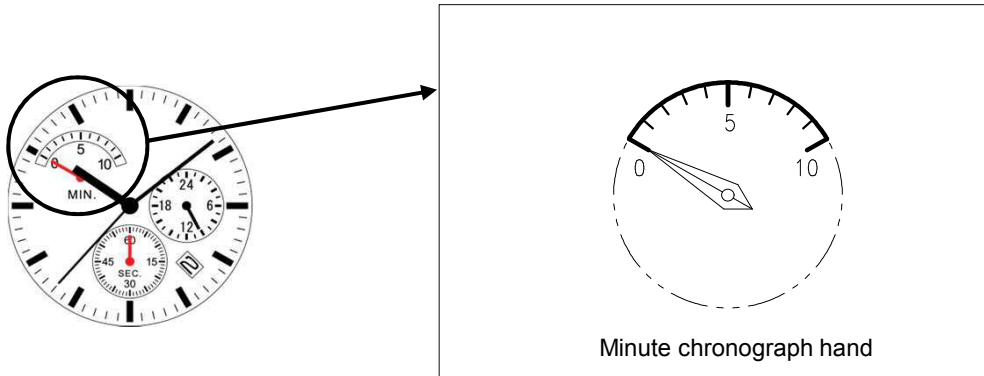

**(1) Chronograph function**

When the chronograph function is activated, the minute chronograph hand moves 120 degrees from the start point.



**(2) Set to "0" position**

When the minute chronograph hand set to "0" position, the minute chronograph hand turns a full round.

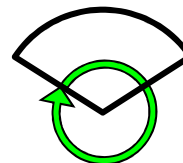

**(3) Dial index design**

The dial index must be designed on the assumption that the minute chronograph hand turns a full round.

**2.The start position of chronograph hand**

The start position of the minute chronograph hand can be set on the arbitrary positions in the range of 360 degrees.